

tinyènin sen kelen jò
nkalon kulu b'a bin

hère sòrò shaw kalan

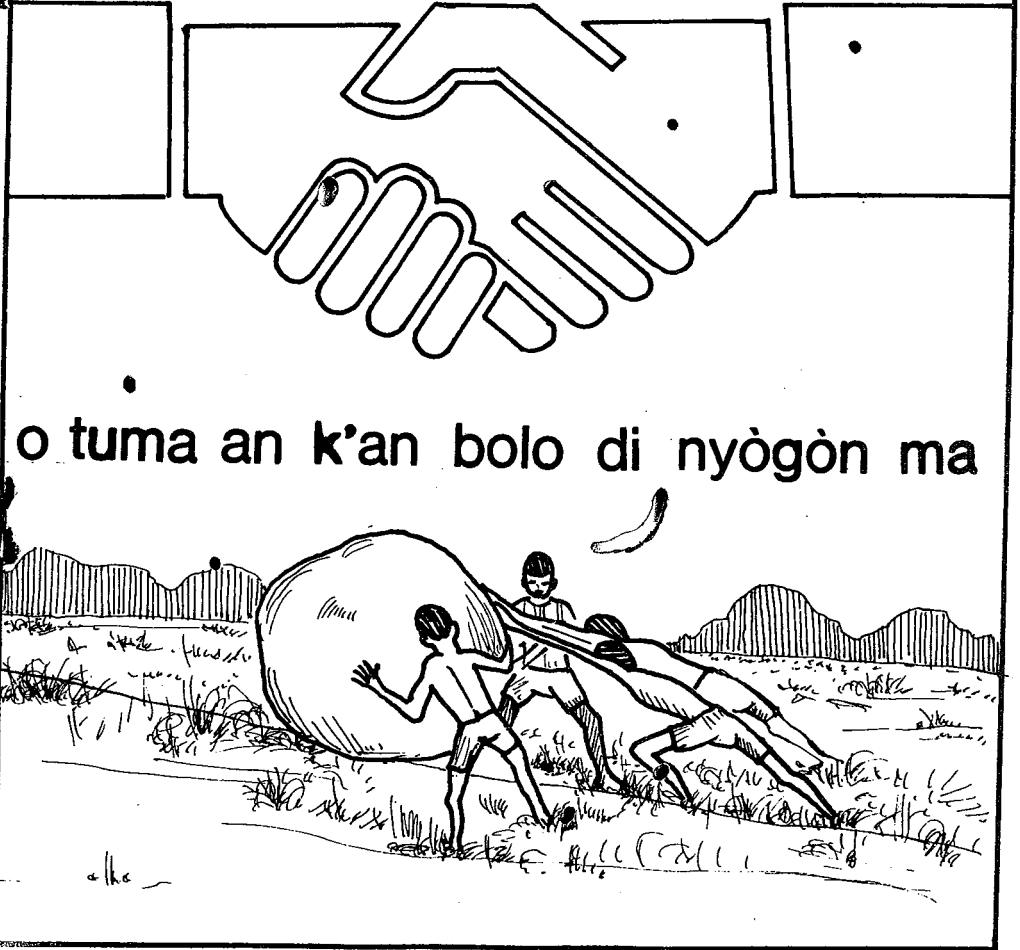

ka baara kè

nin gafe in sèbèna ka di animatèrèw ma, minw bè yaala ka m̀g̀d̀w lad̀nniya dinyelatigè cogo nyumanw la, saniya ani kènèya hukumu k̀nd̀.

gafe in bilalen bè fana m̀g̀d̀ bolo kan, minw ye karam̀g̀d̀ ye koperatiwu k̀nd̀, ani fèn o fèn bè se ka kè sababu ye ka jama kalan konyuman, k'a don sira ia, min bè a ka hère sinsi kosèbè, ga k̀nd̀, dugu k̀nd̀, ani jamana k̀nd̀.

nka, gafe dama t'a ye. aw minw b'a baara kè, aw de ye kalan in tuloma ye. aw ka kan k'aw hakili jakab̀d̀, ka fèerèw s̀r̀r̀ kalan kè cogo la, walasa m̀g̀d̀w k'aw faamuya.

kalansen minw bè gafe in k̀nd̀, aw bè se k'u tila k'a kè kè ko fila walima saba. kalan in kè ỳr̀r̀ la, aw bè ko bèe kè ka kalandenw nyagali, ka s̀s̀d̀li wuli, min bè laban tinyè kan. o b'a to, k̀r̀d̀f̀d̀ caman bè to kalandenw hakili la.

aw bè se k'a f̀d̀ fana ko kalandenw k'u nyè na kalansen sugandi. n'o kèn, aw bè o kalansen in kè kalandenw kun.

an ka foli ani tanuni bè aw ye, aw minw bè aw ka d̀nniya tila aw ni m̀g̀d̀ wèrèw cè, walasa an ka jamana ka b̀ nèg̀ la.

n'i bè kalan in kè yòrò o yòrò, i ka kan ka ko bée kè, walasa kibaruya kalannen caman ka to mògòw hakili la.

aw dun b'a dòn,

kalan kèlen min bè to tulo la, o te bèrè ye. nka, nyè bè min ye, o caman bè to mògò hakili la.

n'aw b'a fè, kalan in ka sabati, aw bè kalan kè cogo fila kè nyògòn fè : tulo b'a-ta mèn, nyè b'a ta ye.

min ye tulo ta ye, ye aw yèrè kumakan ye.

nyè ta, aw b'o labèn ni gafe in kònò jaw ye. aw bè se k'u kè furajèbaw kan, minw bè tara n'aw bè kalan kè, walima k'u kè ja fitininw ye, minw bè nòrò walanba finimugulama kan.

jaw bonya cogo filè : (aw kana siran ja bebebelew nyè. bari, ja fitinin b'aw tòorò, ni kalandenw ka ca).

jaw bè bonya naanikènyèjòlen fè.

- ja kun fòlò tilatila, k'a kè naanikènyèjòlenw ye. o bè kè ni sèbènnikèlan ye, min nò bè se ka tunun. n'aw t'o fè, aw bè sèbènfura fègèma don a jukòrò.

- aw bè nimòròw sigi naanikènyèjòlenw bée la, cii dalen ani cii jòlen fè. aw bè ja bonya furajèba min kan, aw b'o ta ka naanikènyèjòlen hakè kelen cii o kan.

misali dò filè :

ni ja kun fòlò naanikènyèjòlenw kèrèw ye santimètèrè kelen kelen ye, aw b'o kè santimètèrè duuru duuru ye.

- o kò fè, aw bè ja fila singa nyògòn ma, ka finyèw latilen, ka ja in laban.

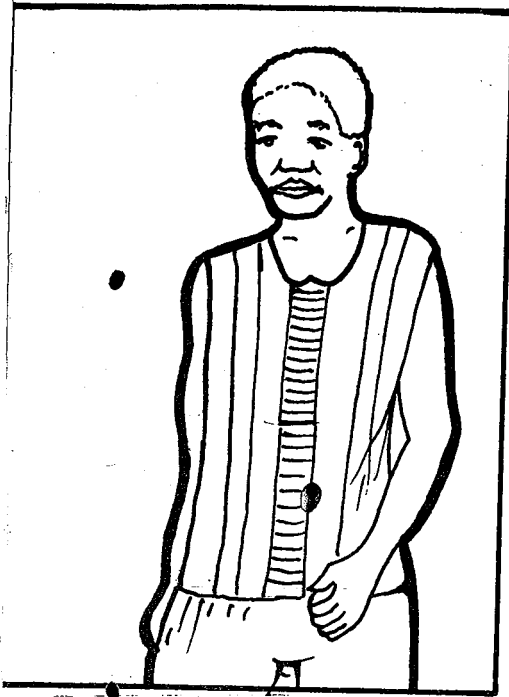

mògò kelen kunna man di.



hali ni ñaniya nyuman ani barikaba
b'i la, mògò kelen tè fèn ye.

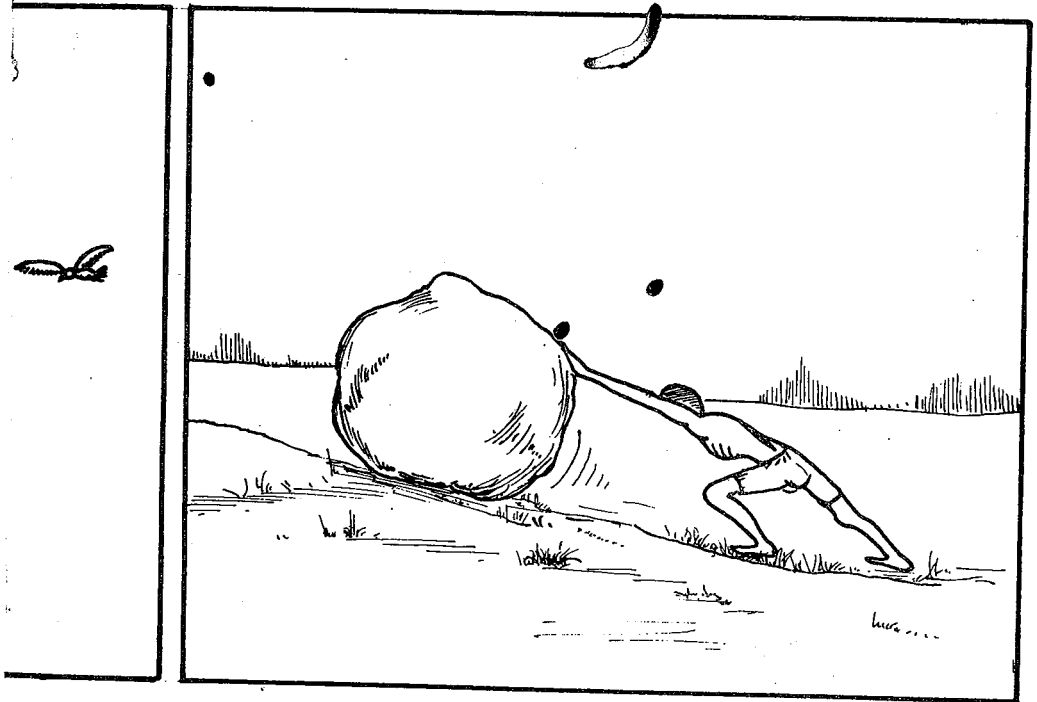

a fòra i ye ko mògò kelen barika tè fèn ye. bolonkòni kelen tè bèlè ta.

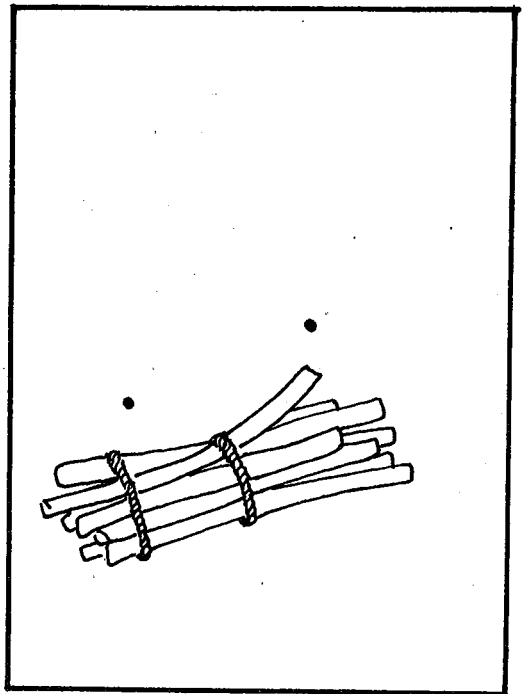
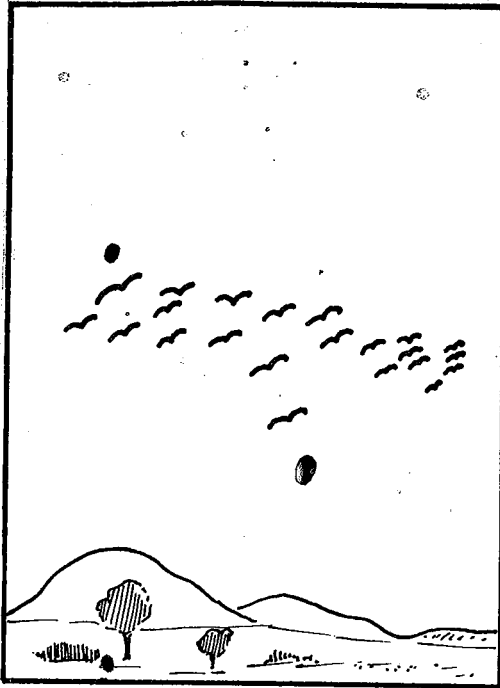

n'aw farala nyògòn kan, aw bè barika sòrò, i n'a fò, nin dọ̀gòsiri.
bari, nin kari ka gèlèn

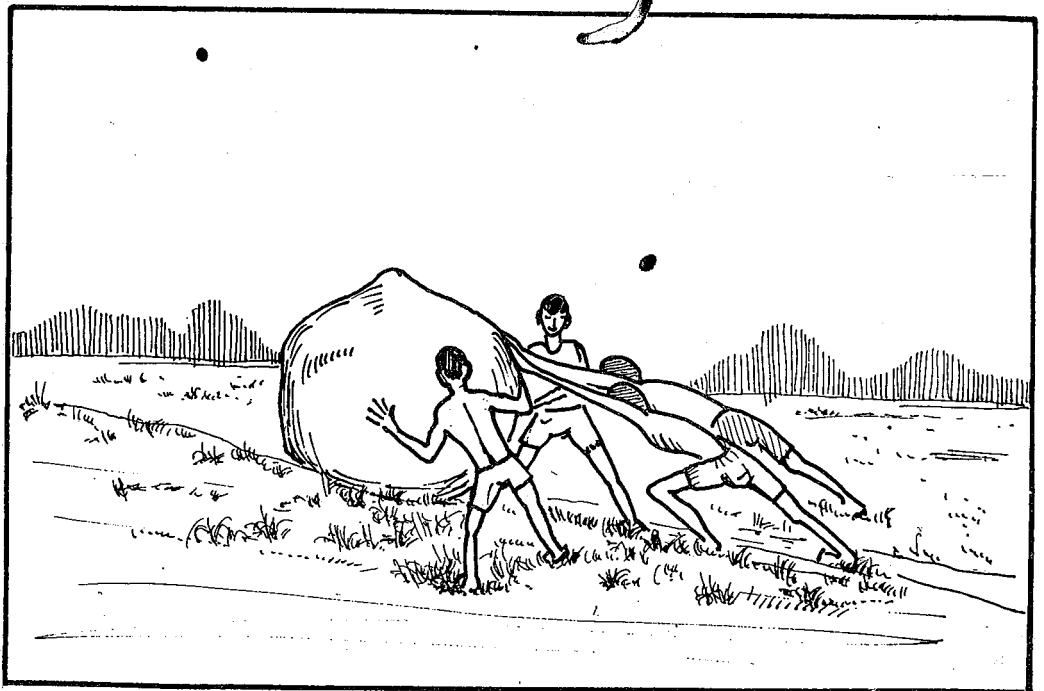

bamananw ko ko kòndòw jèrèlèn bè bii fò.

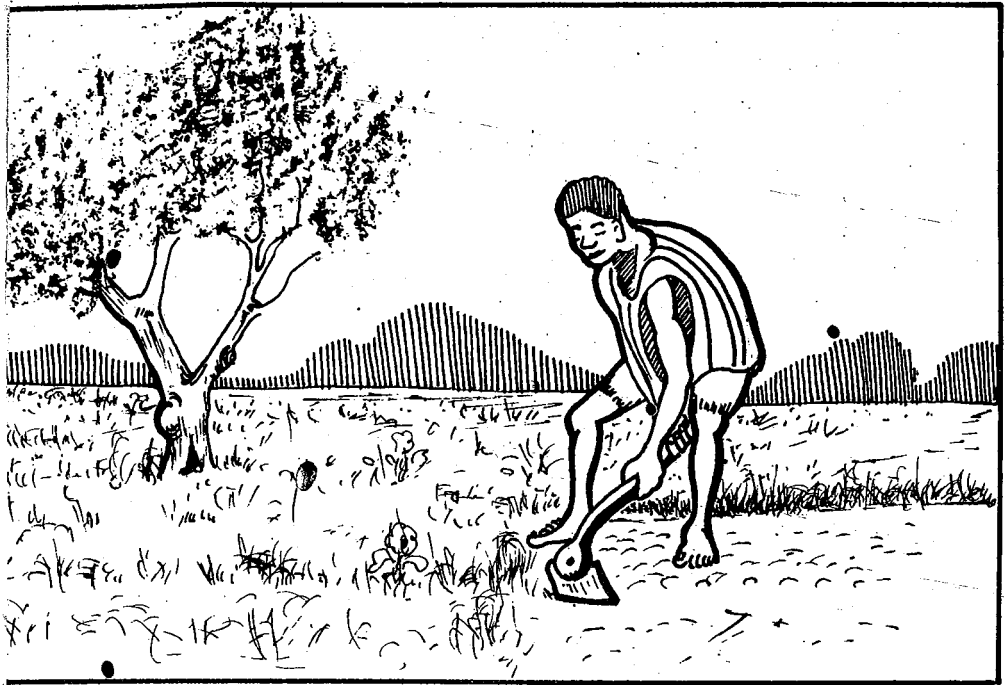

è. e kelen n'i ka daba kurunin bè se ka nafa sòrò sènè la wa ?

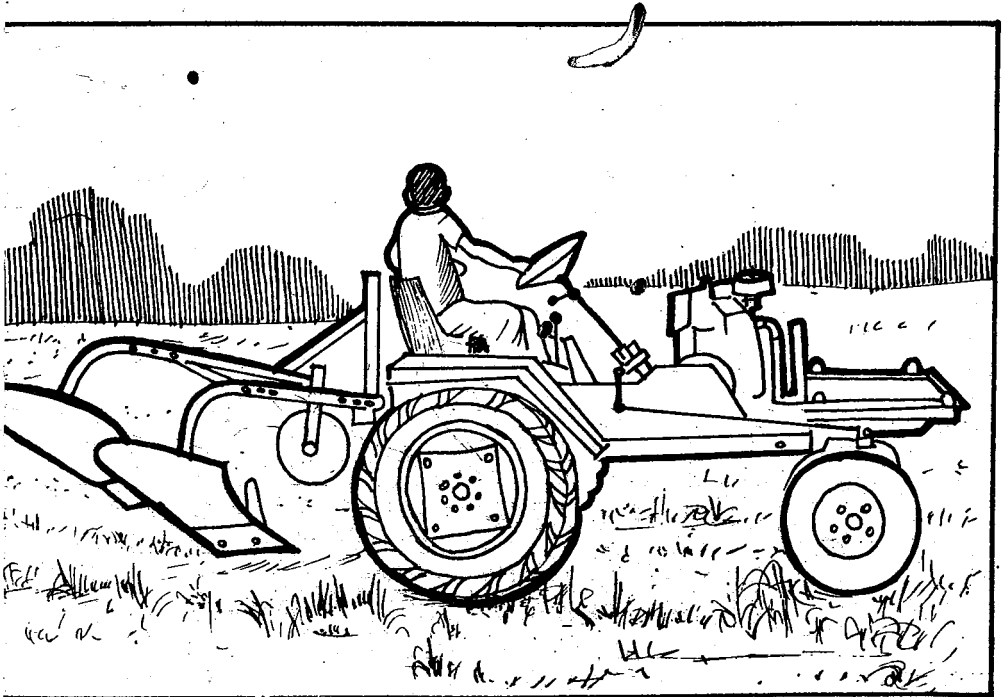

n'aw jèra ka sènèkè koperatiwu dila,
aw bè se ka cikèmasiñ san, ka forobaw bò, ka nafa caman sòrò cikè la.

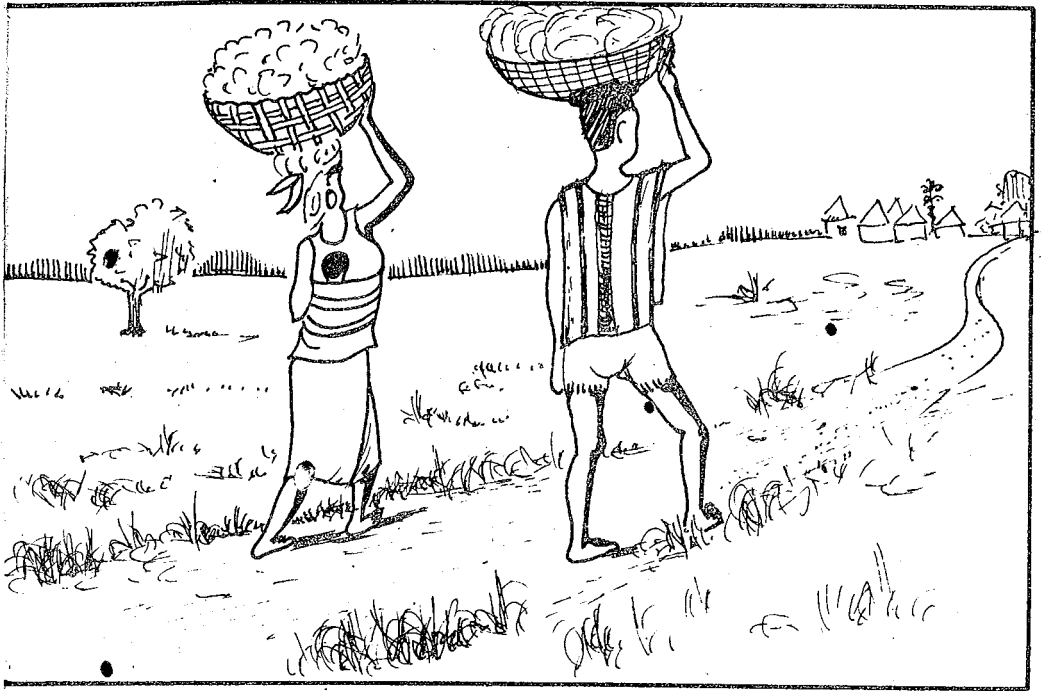

e kelen n'i ka gadenw dama bè cikèfènw doni aw kun na.
n'aw tèt, tów bèe lafiyalen don.

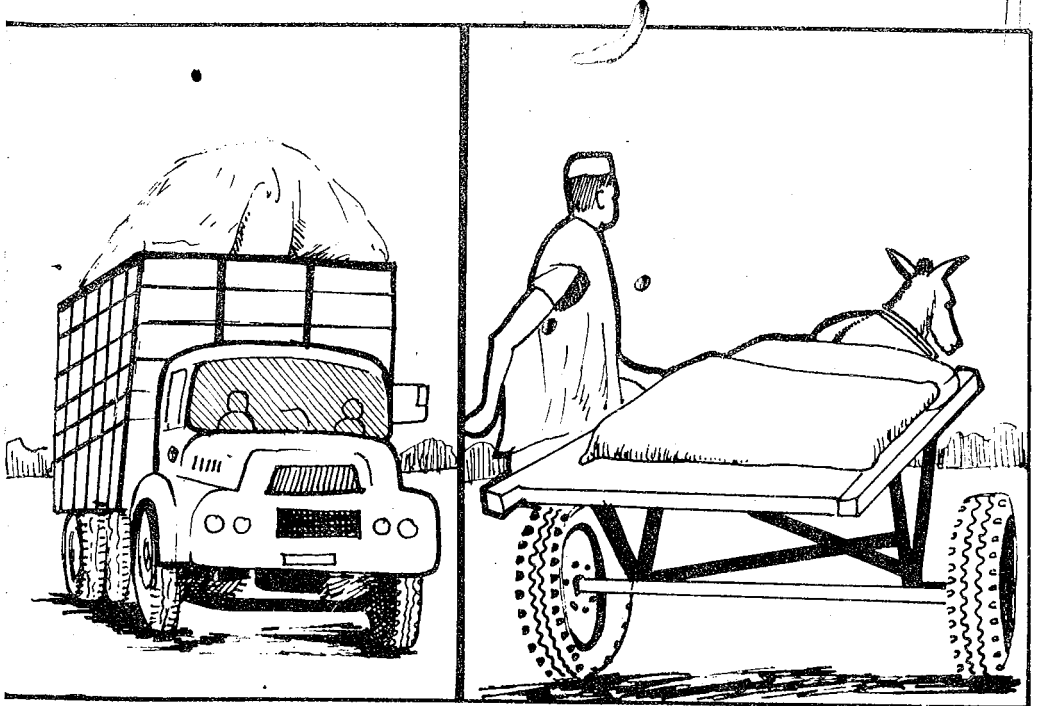

minw jèra ka koperatiwu dila,
olu ye mobili ani wotoro san cikèfènw donini kama.

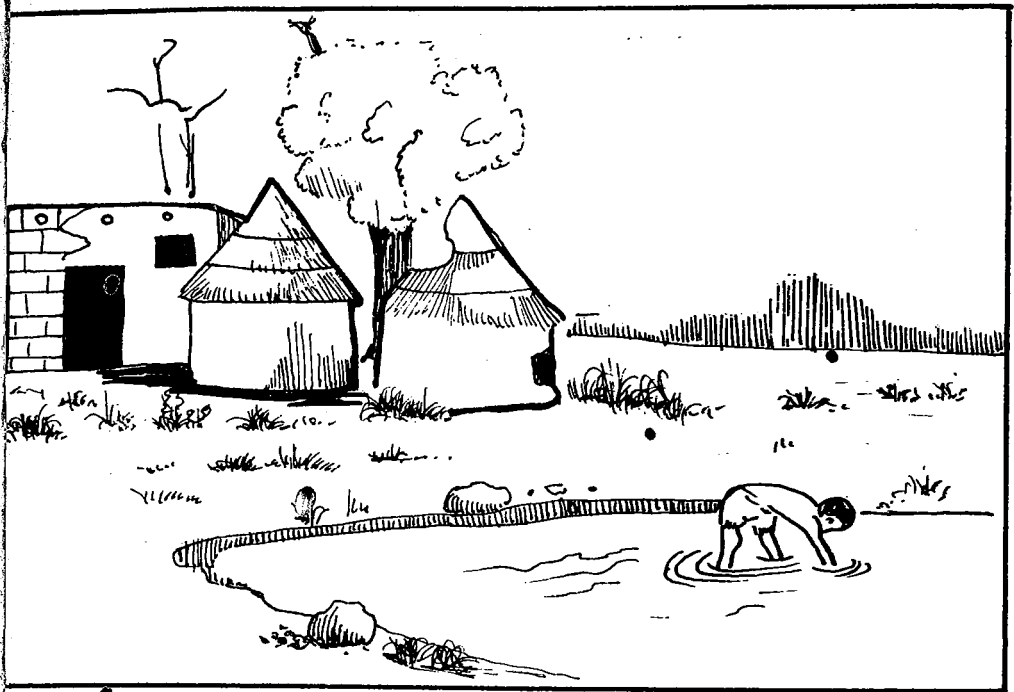

mògò kelen bè se ka hère lanati ga, du, walima dugu kònò cogo di ?
wajibi ye sègèn ni tòorò ye.

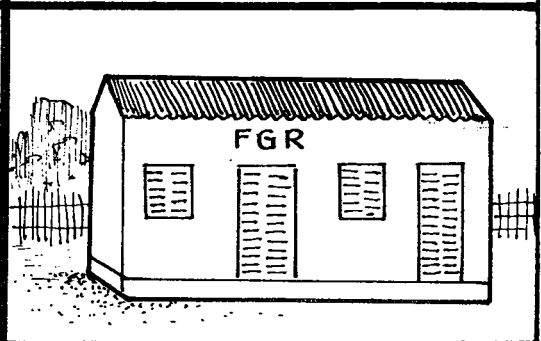
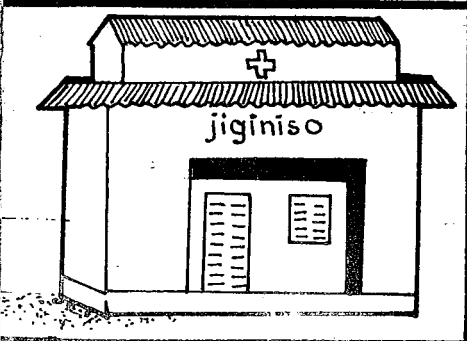

koperatiwu sigilen nafa nana n'anw ka dugu dilali ye.
anw bè ala tanu. bi, anw jèlen ko : alamudulayi.

bi, f'an ka fara nyɔ̀gòn kan, ka nyɔ̀gòn dèmè.

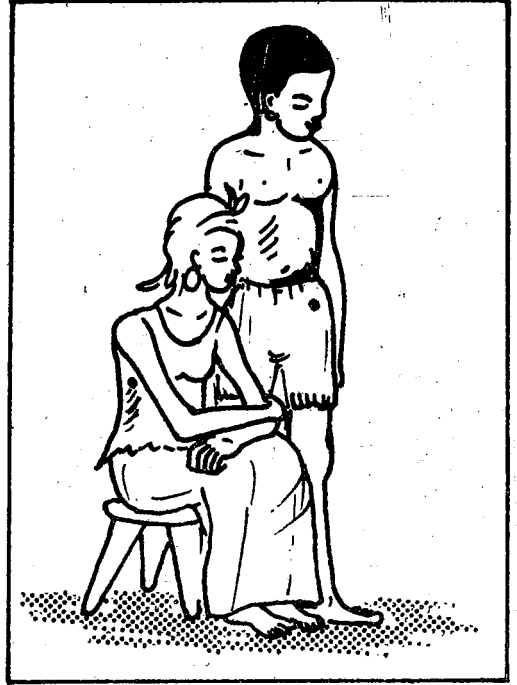

den cāman bè nin cogo in na bi.

banabagatòw ka ca jamana kòndò.

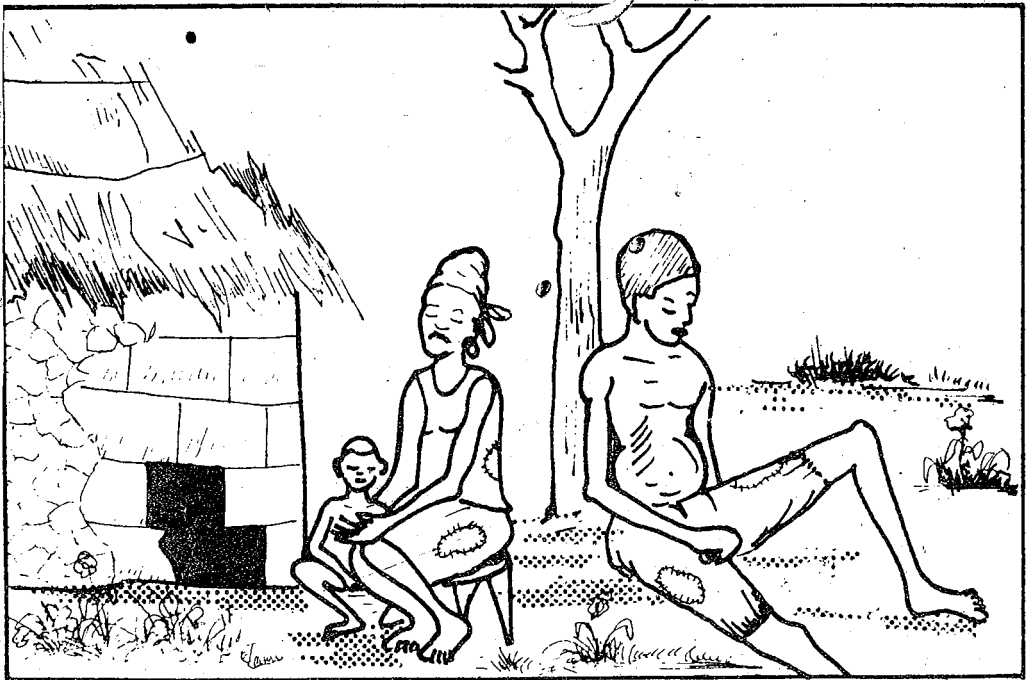

mògòw bè yen, dumuni t'u bolo. si yòrò nyuman fana tè yen.

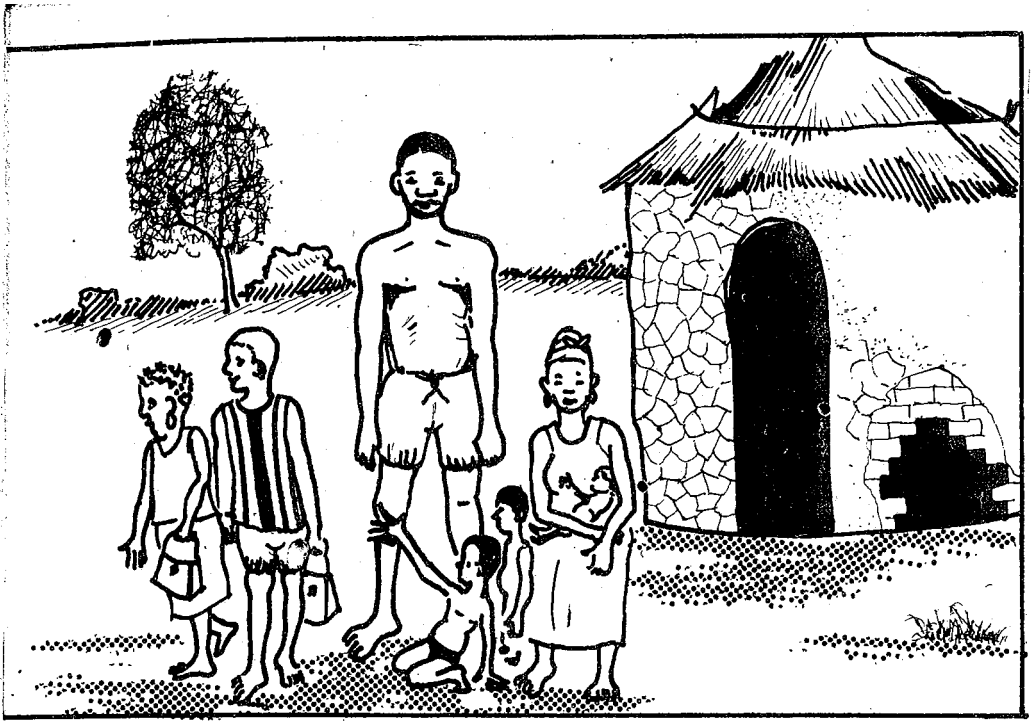

bangebaga caman bè yen, minw dèssèra k'u denw don kalan na.

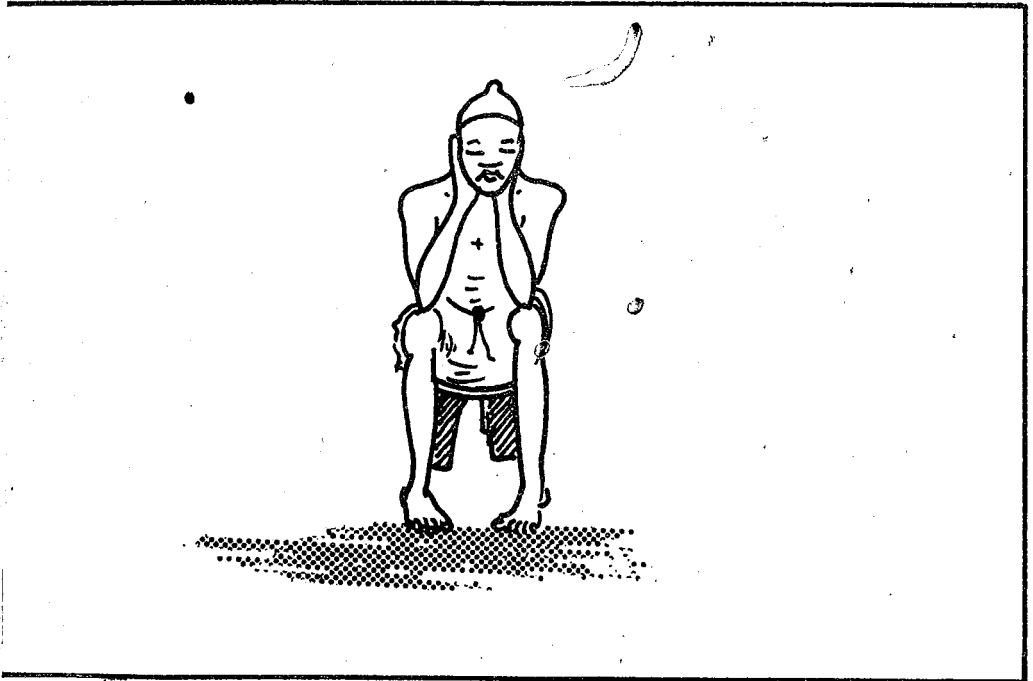

mògò caman dusu kasilen bè sègèn ani tòrò bolo.
a fò, u bè se k'u ka dinyèlatigè tò kè ten ?

bi, bée b'a nyini k'i ka du hère sèmentiya.
o bè sòrò mun fè ? f'an ka fara nyògòn kan ka baara kè.



ni hère nana,
den barikalamaw bè sòrò,

farikolo kènèya bè sabati,
banaw bè nògòya.



balo caman bè sòrò, an b'a nyuman dun k'an fa.

nyan o'ji esal, id
at nyan b'ò: ka o

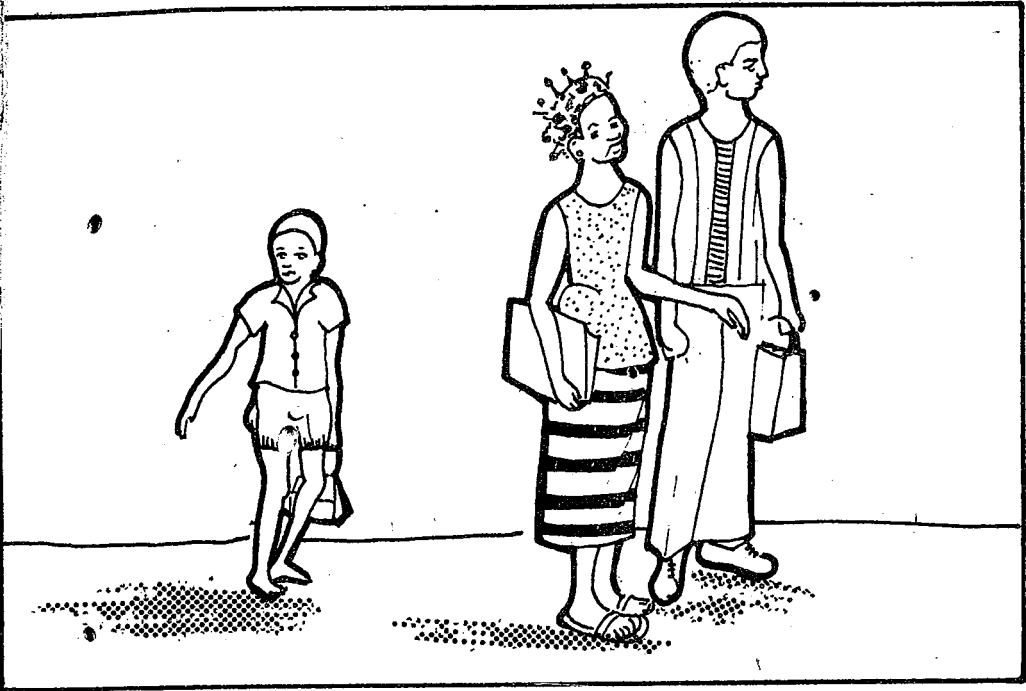

o tuma, denw bée lamò cogo bée nyè. bari, u bée bée don kalan na.

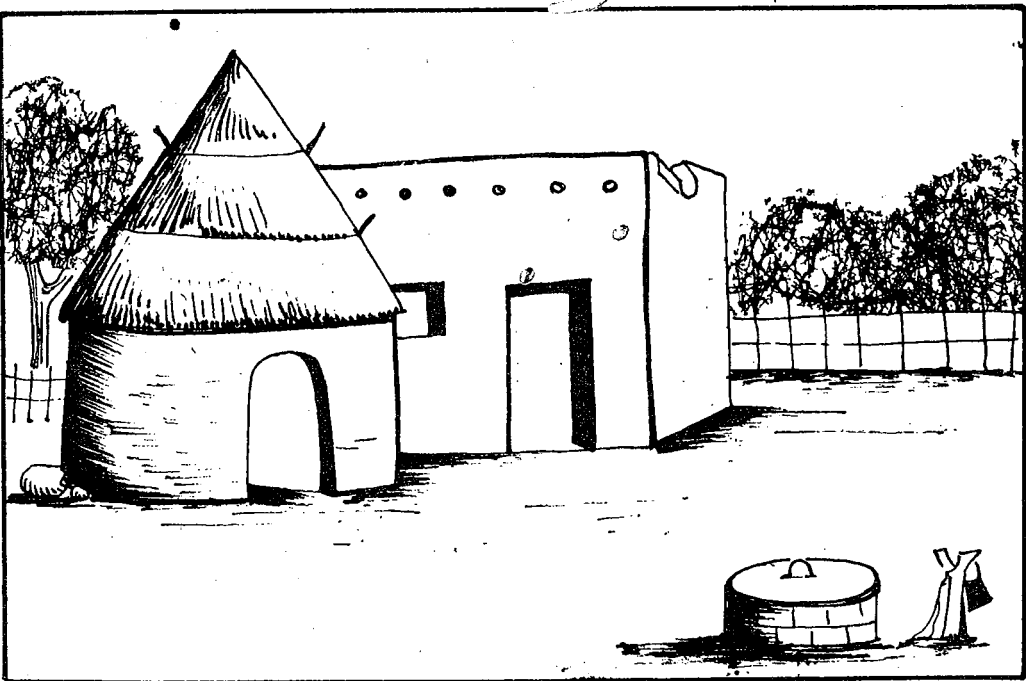
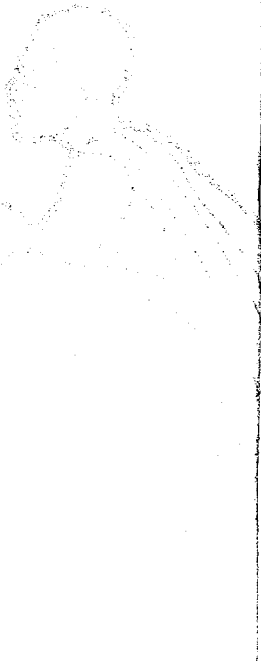

so nyumanw bée jò du cènyi kòndò. dusukasi bée ban pewu

cikèforo ni ga bèè dama ka kan.



ga bè kòmi foro sènèta. i b'i hakili to
a la waati bèè la.
foro bè sènè cogo di ?
i bè fòlò ka dugukolo labèn, ka sòrò,
ka danni kè. dannifènw bè falen. fa-
lendenw bè kòròbaya, ka sòrò, ka den.

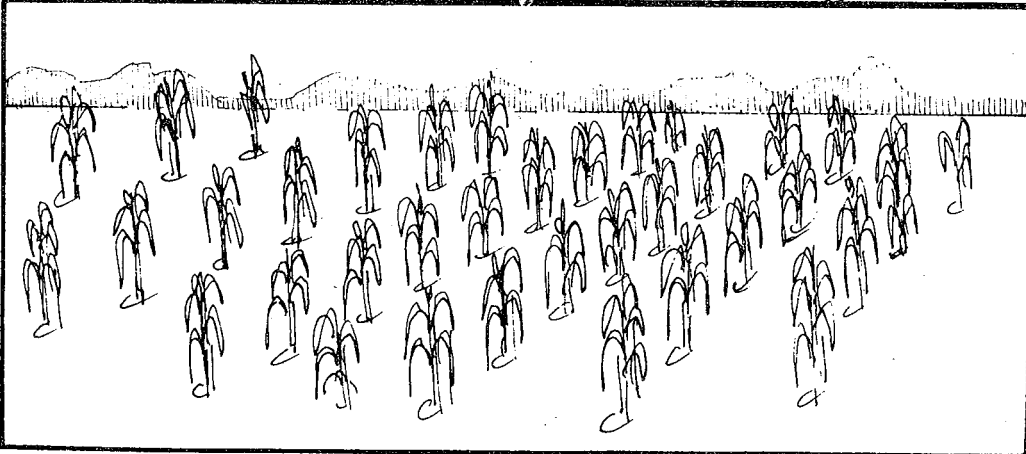
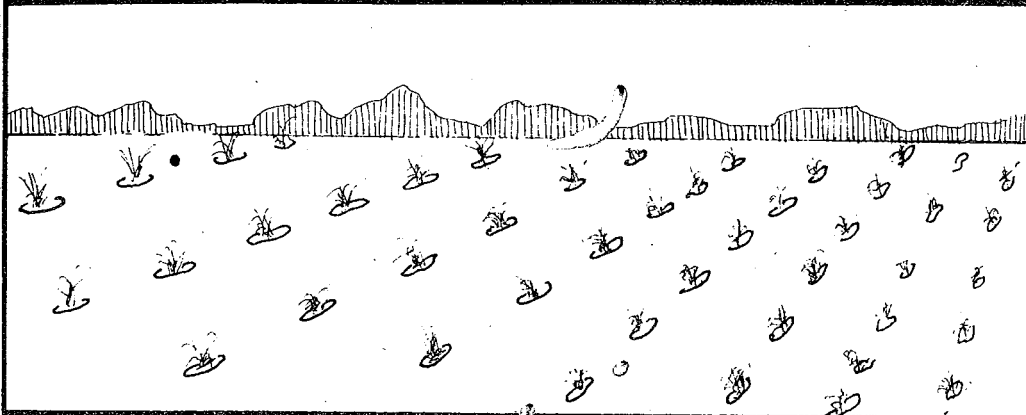

nin foro in kòndò nyò ferunnen don. a nyò in te nye. mun na ?

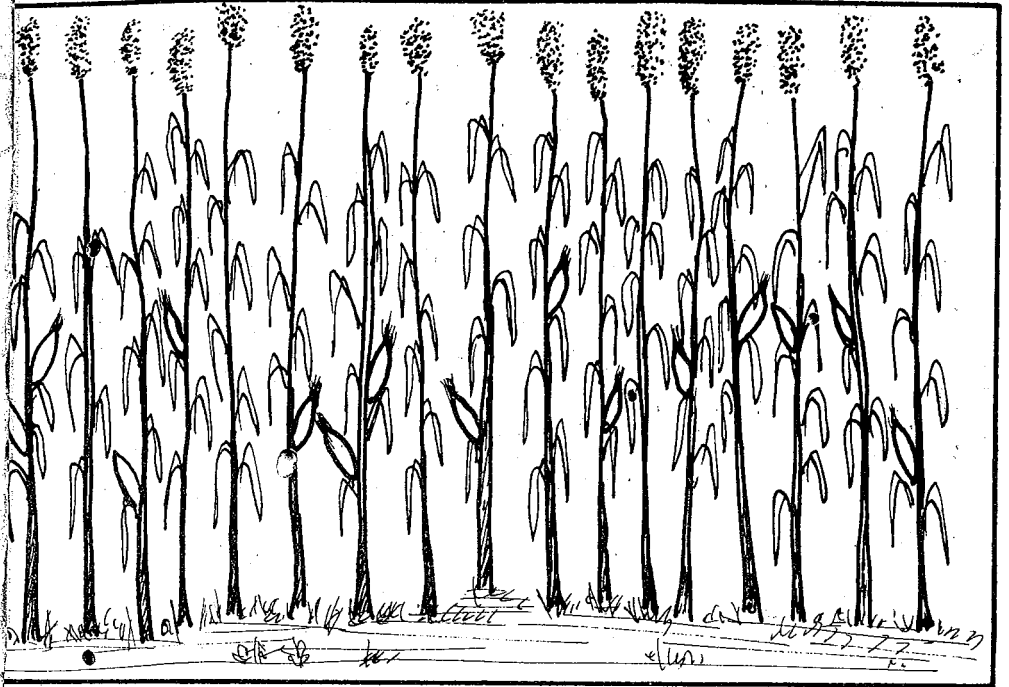

foro wèrè filè. falendenw ma ferun hali dònì.
o nyò bè nyè kosèbè. bari, nyò in tinsanw ka bon.

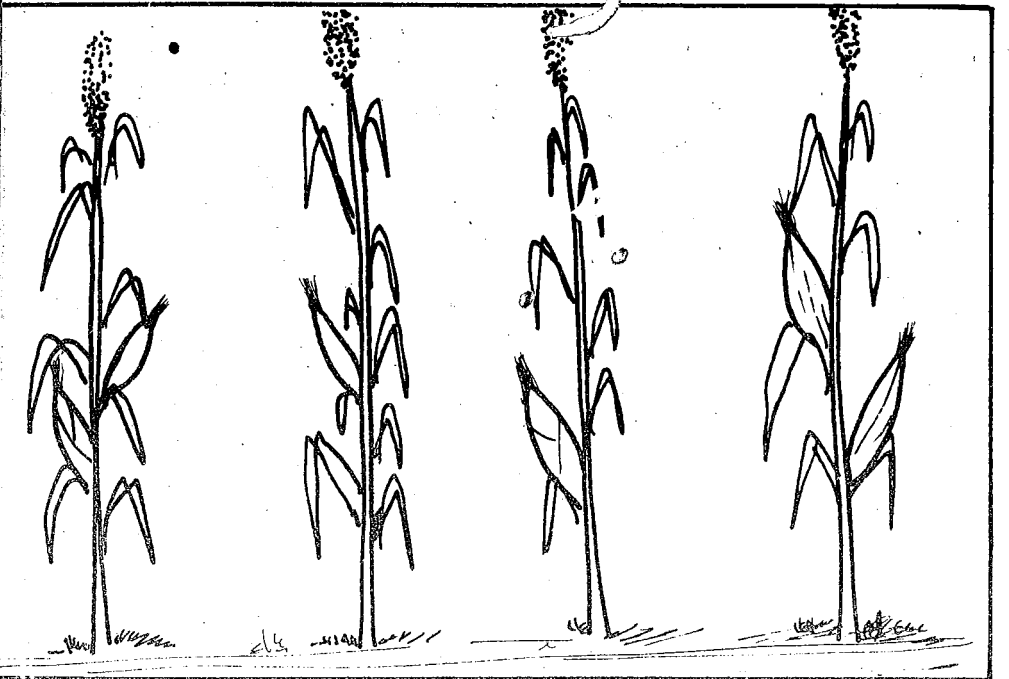

awa, ga kòndò, ni muso kèra seremuso ye, denw bè tugutugu nyògòn na.
u tè barika sòrò : tuma bèè, bana misèn. u ba fana t'a yèrè sòrò abada.

n'i bè foro kelen sènè kudayi...

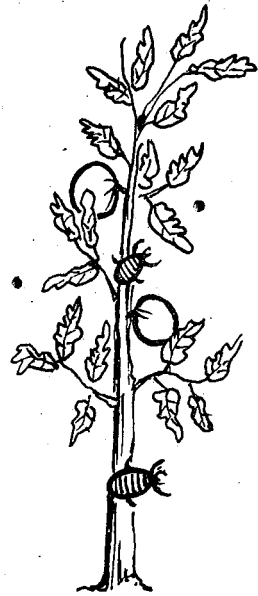

iriw falen cogo bè gèlèya ka t'a fè. jiridenw fana bè dògòya dònì dònì,
a na laban k'u tinyè. jiri falenni konyuman bè sòrò dugukolo nyumanya fè.
i nògò bè dugukolo la, fèn bèe sènènen bè nyè.

i hère bè ga kònò, gadenw bèe, fa wo, ba wo, den wo, bèe b'o dòn. balo
yuman bè na ni kènèya ye.



ka kan ka hami n'i denw balo konyumanya ye.

denw cayara ga kônô, mun ni mun bè kè ?

eremuso ye denw ba ye, muso in bè sègèn. bari, den caman wolo tè tò to
o la. den ladon konyuman ani baara taw, i n'a fò, forola taa, dögô nyini,
oni. o baaraw bè muso barika ban jona. kosala denw si tè barika sòrò,
tuma bée, u bananen don.

kônôbaraw ma tugu nyôgôn na, muso ni bè lakana. a bè se ka fari sòrò, a
w fana bè bonya. den barikama mò ka di, a bangebawaw tè tòrò fana.

wale minw man kan ka kè.

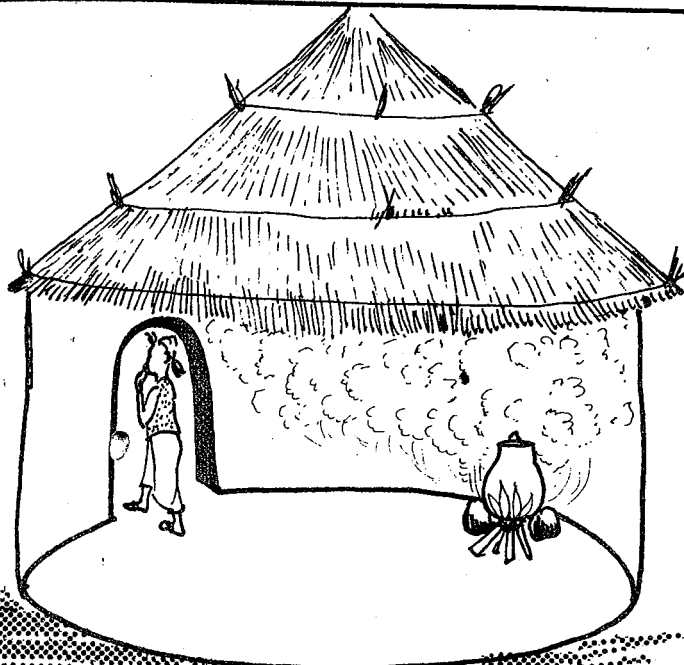

ka finfin mènè i siso kònò, i da tuma,
o wale sugu bè mògò faga yòròn kelen.



ana sòn ka don kamiyòn kònò ka taa dugu la.
n'o kèra, i kònò bè se ka wolowolo.

i kana doni girinman ta.

wale minw man kan ka kè

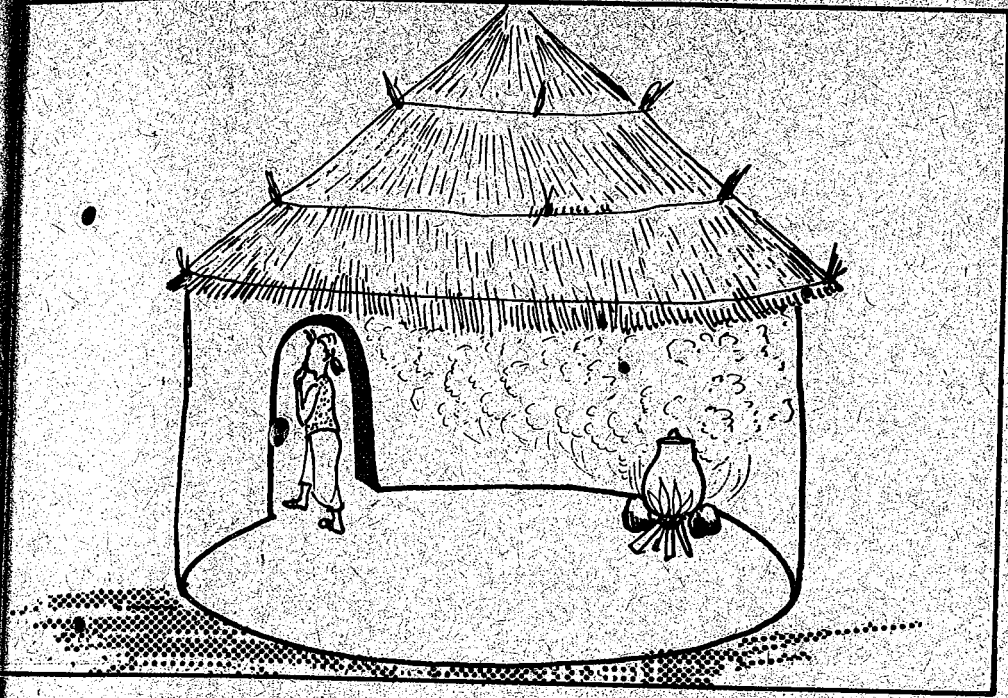

ka finfin mènè i siso kònò, i da tuma,
o wale sugu bè mógò faga yòròn h kelen.



kana sòn ka don kamiyòn kònò ka taa dugu la.
n'o kèra, i kònò bè se ka wajowolo.

i kana doni girinman ta.



i kana baara gèlèn kè.

kana sòn kèlè ma.
far tulo gèlènw fana ma.

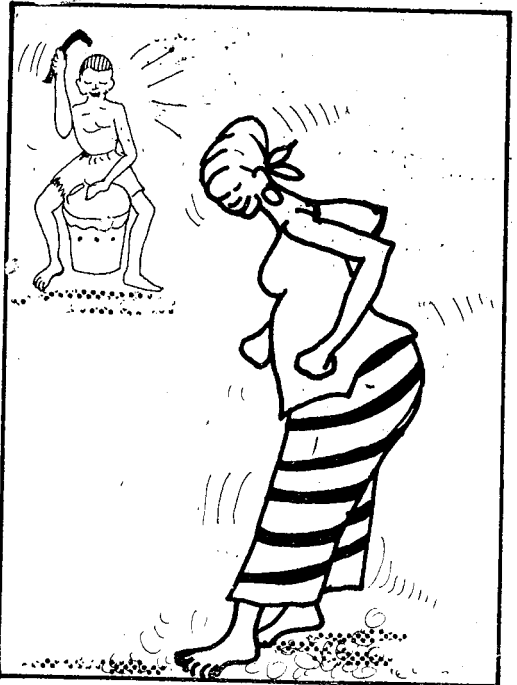

muso kònòma man kan
ka sira ni sigarati ni tabadaga mi. kana sòn ka dòn kè, n'i kònòma don.



n'i b'è finí ko, i b'i sigi.



furanni b'è kè ni furannan kalajan ye.

n'i b'a fè, muso ka bange den nyuman na, i b'a balo kosèbè. o tuma,
a ka dumuni ka kan ka kè balo suguya caman ye, minw bè mōgò nafa.



alo ka kan ka kè nakò kònò fèn sènènenw ye, i n'a fò, nyuguw, karòtiw,
sow, jabaw, tamatiw, ganw, nkòyòw, shòw o n'a nyògònna caman.

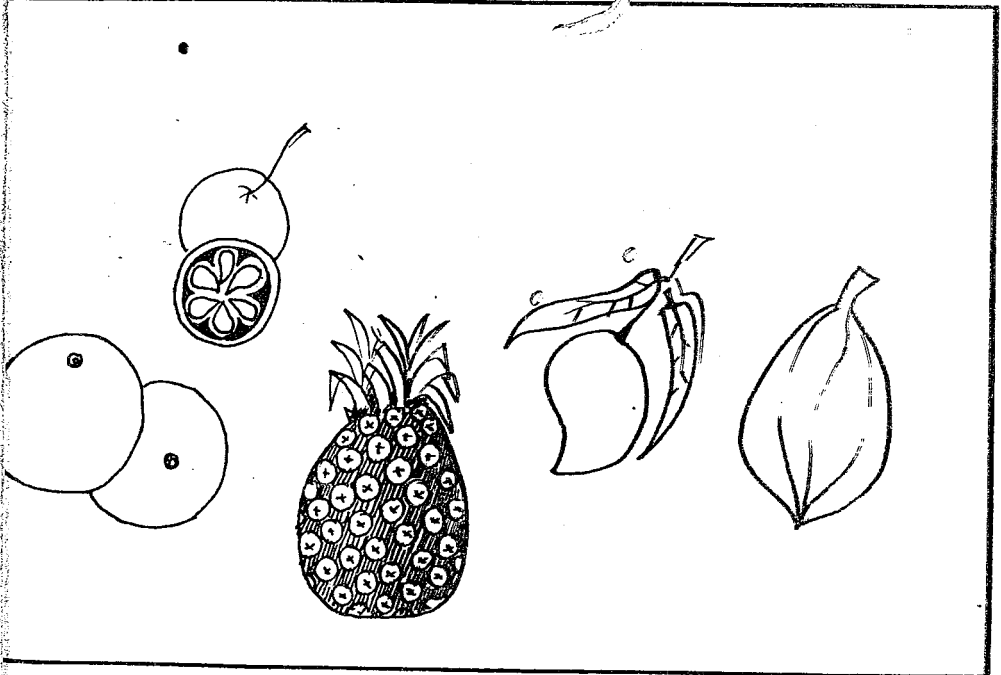

jiriden mòlenw : lenburubaw, madariniw, jabibiw,
manjew, mangorow, namasaw, n'a nyògònna.

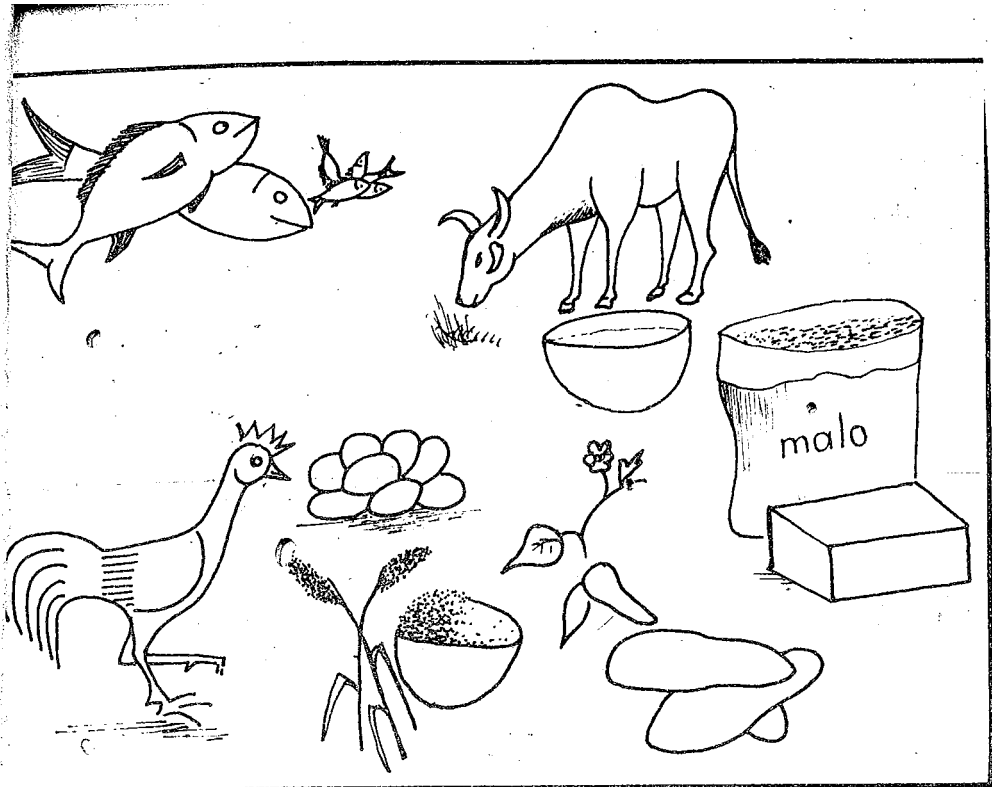

jègèw : a kènè, a wusulen, a jalen. sogo, nònò, dumuni minw bè
barika don mǒgò la : nyò, malo, ku, bananku, woso, sukaro.

• i kan'i balofèn bè feere sugu la.

miiri i yèrè balo konyuman na. o bè kènèya sabati.
i fana dagalen bè ni balo nyuman ye.



fana foronto
taman dun.

i b'i hakili to tulu ni
nare fana dun cogo la.

dòlò man nyi muso kònòma
ma, a ka jugu den fana ma.

ni muso kònòma don...

an y'a fò ko a fari ka kan ka saniya, awa, a ka kan ni balo nyuman ye.
yèrè ka kan ni kènèya ye, walasa den min bè na, o ka na ni barika ye.
o wale bè sèmèntiya cogo di ?

muso kònòma bè taa dógòtòròso la, walima jìginniso la, walima furakè
yòrò min na, a bè se ka filè, ka banaw taamashyèn ye, ka sòrò, k'u
furakè kabini muso lasirili daminè tuma.

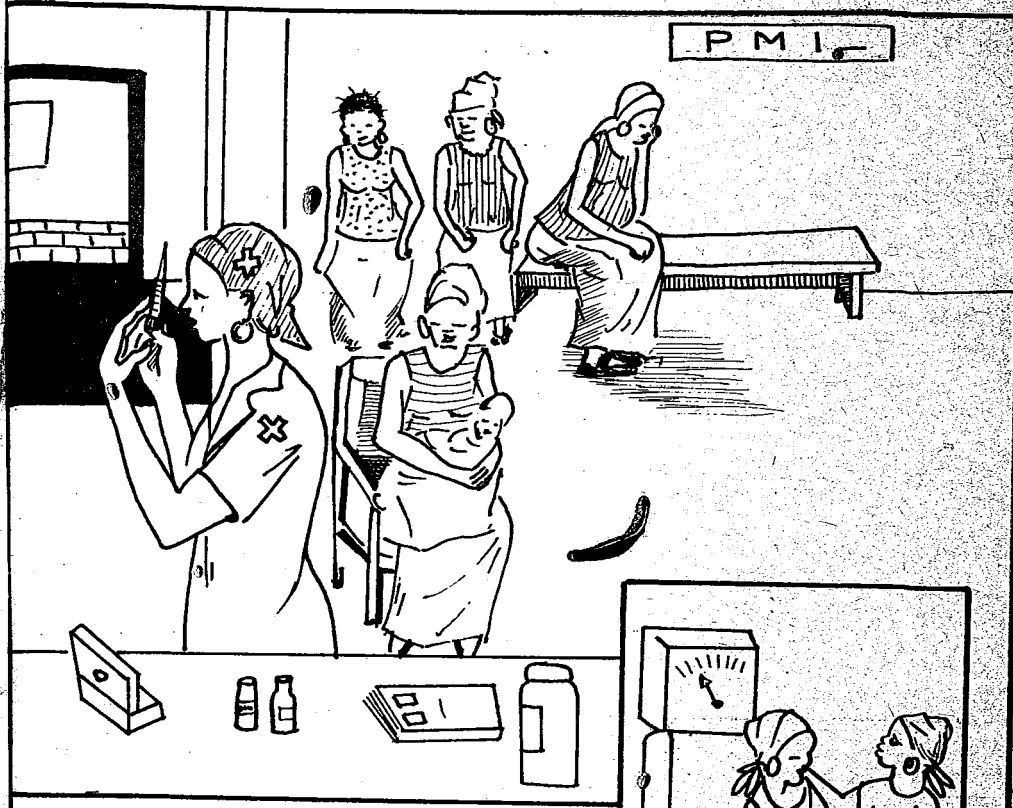

mun na, muso kònòma bè filè ?

a dagalen don wa ?

- a ka kan. bari, bée b'a fè ka den barikama wolo.
- a ka kan. bari, a bè muso tanga sumaya ma.
- a ka kan. bari, a bè muso tanga kasara dòw ma : kònò wolowololi.
- a dagalen don. bari, muso bè jigin hère la, den fana balolen bè na.
- a ka kan. bari, den barikalama bè na. o tuma, bana misènw t'a tòrò.



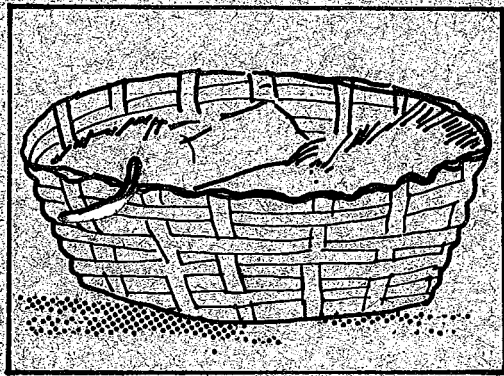
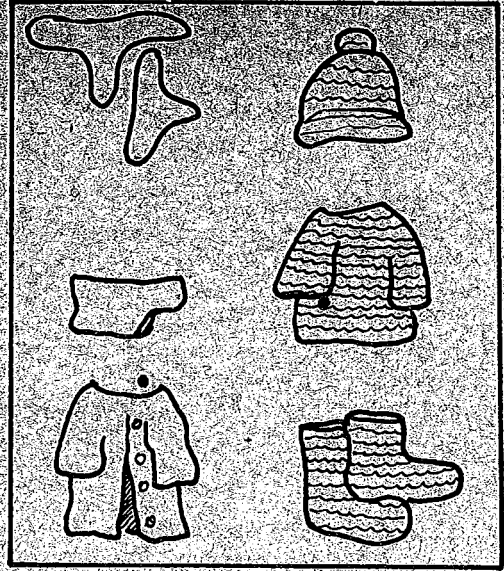

aara sinye caman filèli la
 gòtòròmusow fè.
 aara fana sinye caman
 gòtòròso la.
 ni joli bè bò i kò,
 ni ji bè bò i kò,
 ni barakòròla b'í dimi,
 ni farigan, walima kunkolodimi
 ni la.

i ye jiginni nyèsigi, ka minenw laben,
 min ye :

- finikolo saniyalenw,
- den dulòkiw, sabaraw, ani
nènè waati fugulaw.
- den da yòrò fana bè laben.

jigin tuma surunyana.
aw ka kan k'o wale nyuman in labèn.
ni jiginni kèra so, den kura bè nyèsigi ni...

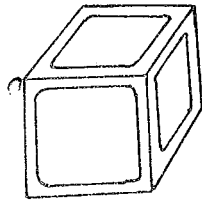

tinminèmuso ka tégèko
safunè ye.

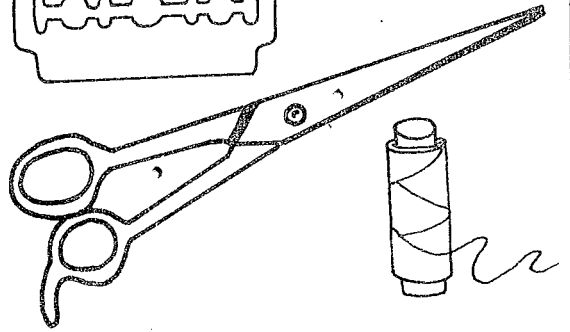
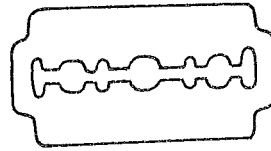

sirife kura kelen, walima kèmsu min bè
kè ka barajuru tigè. gaari balabalalen
ka kan ka kè ka bara in siri.

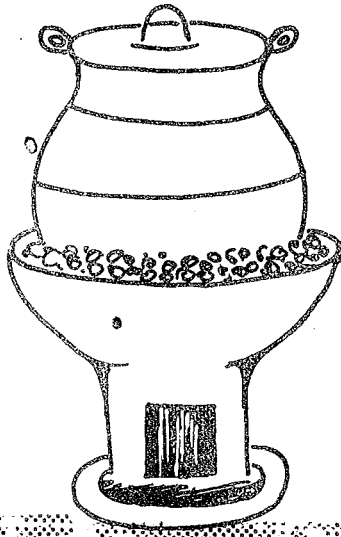

ji wulilen bè labèn jubatò ani
den kuranin kama.

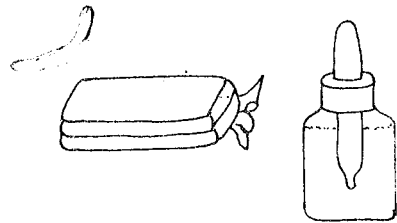

kòori nyuman ani furaji
min bè kè den nyèw la.

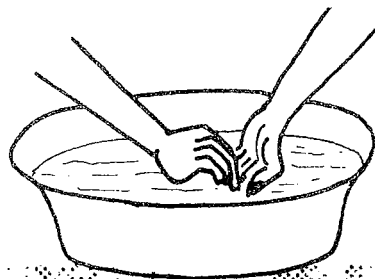

tasa kolen kelen bè labèn.

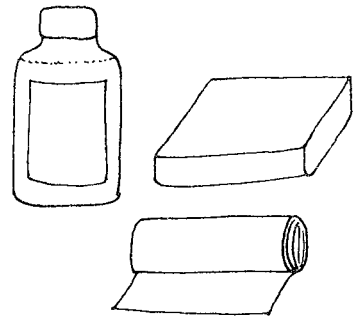

alikòli ani finimugu fègèman,
ka fara jolisiri finimugunin kan,
min bèna kè ka bara siri.

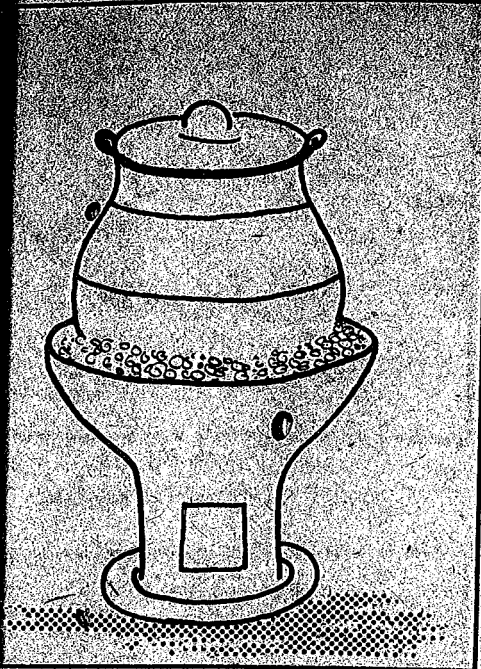

h ba' bē ko ni ji wulilen wōlōwōlōlen
fura bilenman min ye pèrēmanganati
o'ddōni bē kē ji la.
bēe kò, finik'olo kolen nyuman bē don
woro fila cē.

kana dumuni girinman dun,
walima ka fen caman min.

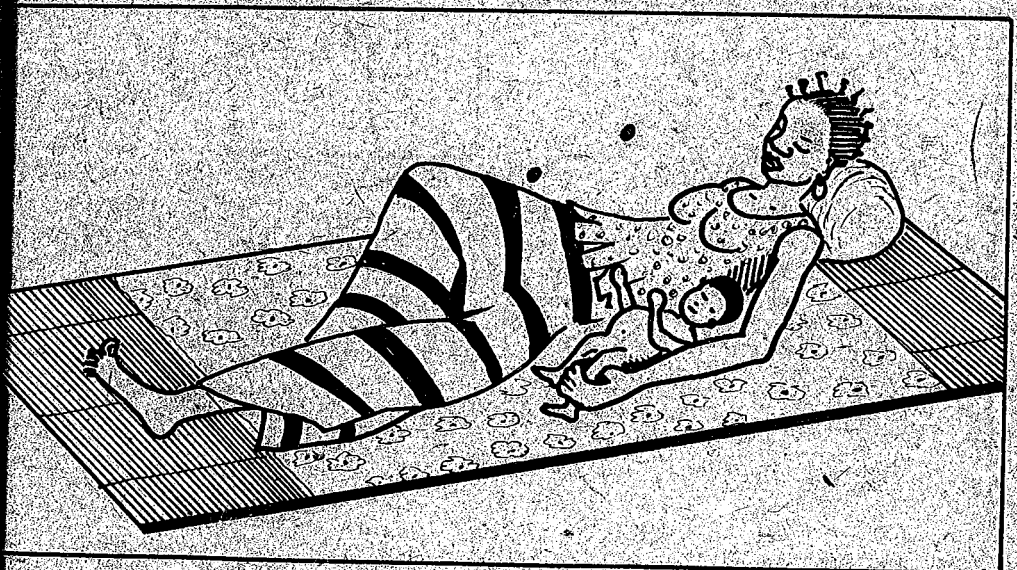

da, walasa k'i fari lafiya. i b'a fō tōw ye k'u kana i tōorō ni mankan ye.

ƙiƙinnin kàlèn kò...

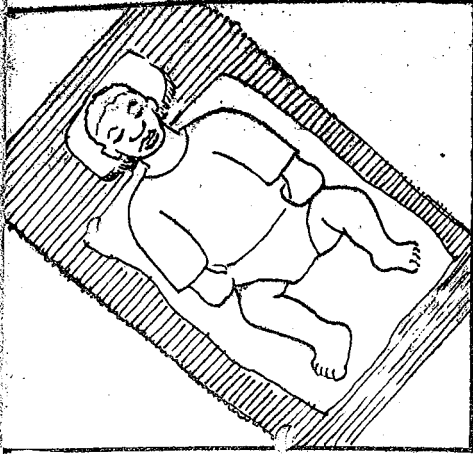

den bè da k'i jan,
walasa a kòkolo ka tilen.

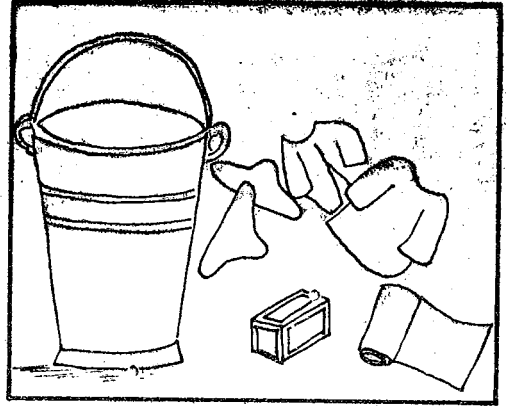

den bè ko don o don ni ji kalan ye,
k'a ka finiƙ falen.

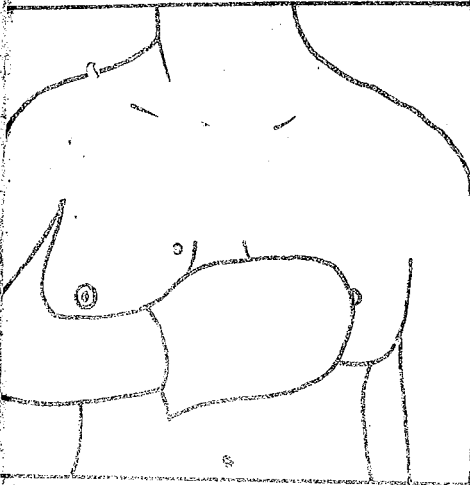

ƙin nunkunw bè ko ni ji kalan ye,
yanni den k'a min.
u bè ko tugunnin ƙin minnen kò.



den ka kan ni lafiya ye,
n'a ye ƙin min ka ban.

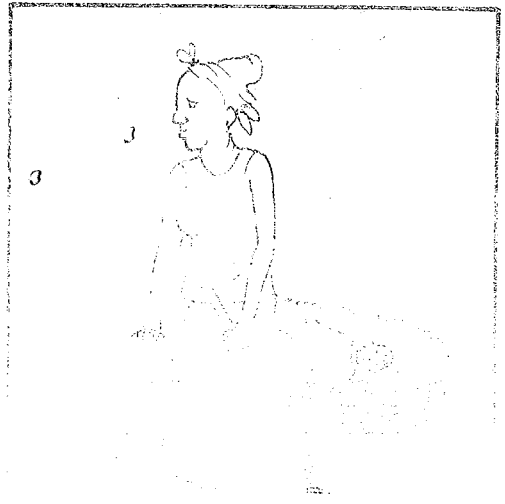

den wololen tile damadama kò...
 jubatò mana lafiya kosèbè, a bè segin ka taa filèlikè yòrò la
 dōgòtòròmúso w fè.
 mun na, o dagalen don ?
 filèlikè in bè na ni laadilikan ye ka bō dōgòtòrò yòrò, minw
 bè muso n'a den ni lakana, k'u kisi farigan misènninw ma, i
 n'a fò, jòntè. jubatò bè den balo cogo nyumanw dòn.

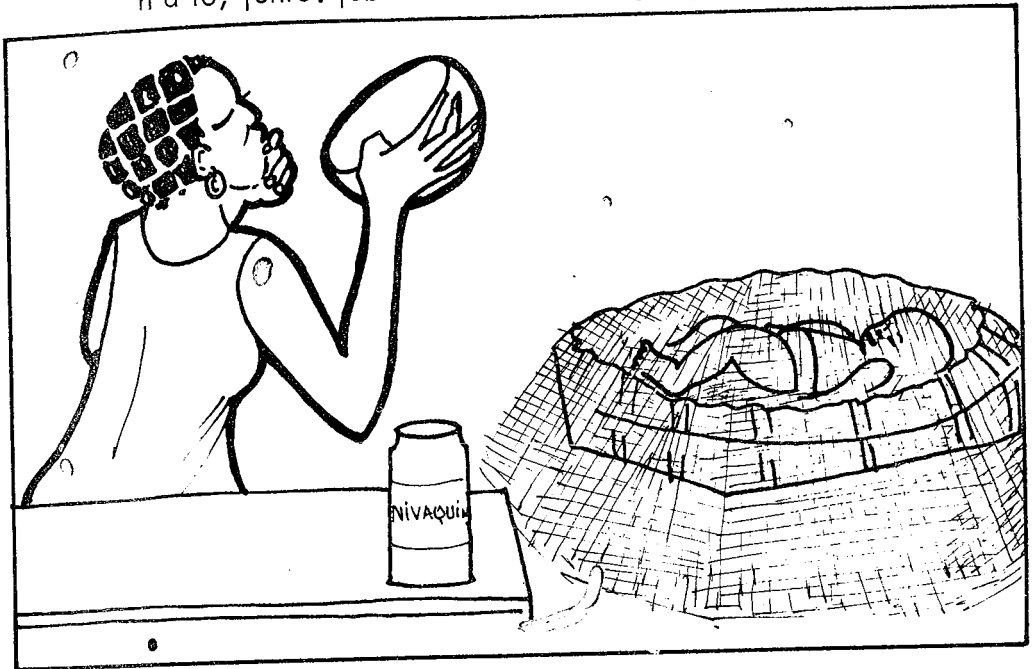

muso bè taa waati bèe la filèlikè yòrò
 la, fo den bara ka bin.
 awa, den bè pese fana tuma caman. o
 b'a to, n'a bè dòn k'a bè fari sòrò.
 den boloci wajibiyalen don ba fè, wa-
 lasa a ka kisi sògòsògòninjè ma, ani
 den misènw ka bana wèrèw ma.



den kòlòsili b'a kisi kasara caman ma...

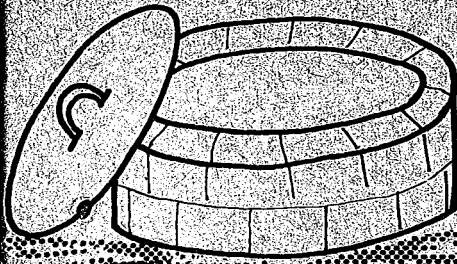

i hakili to kòlòn na.

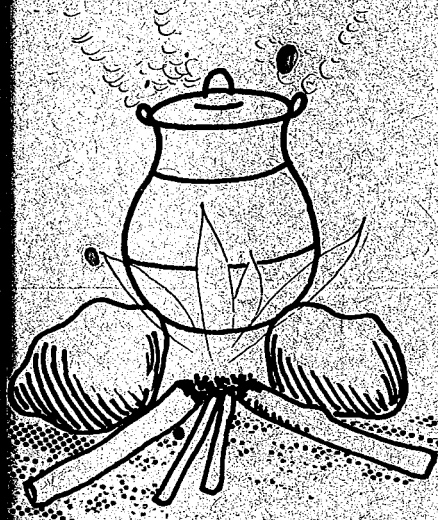

i hakili to fasu a la.

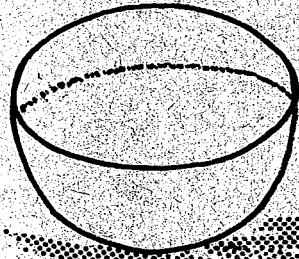

i hakili to ji wulilen na.

fèn damadama bè yen, minw man nyi den bolo kòrò, i n'a fò,
kèmèsu, muru, miseli, pònti, pèngili, takala, fura, finikolan.

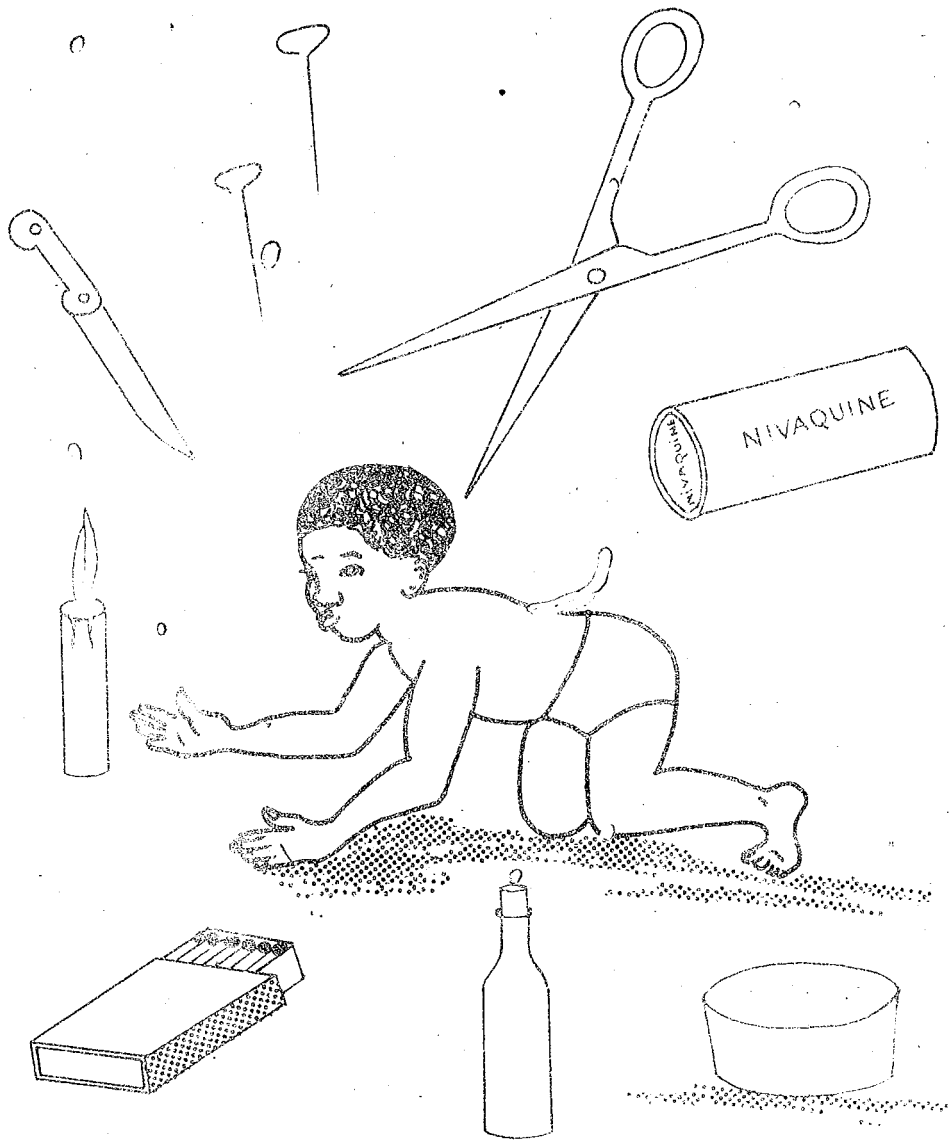

den ka hère kama,
i b'a tanga binni ma, tasumajeni ma, joli ma, ani donnkòndò ma.

denyèrenin ka dógòtòròso filèliw.

n'i b'a fè, den ka mò diya, i b'a pese, k'a suma tuma bée.

filèlikè yàò la, den ba bè laadi sinmìn cogow la, ani dumuni di cogow den ma, n'a dabò waati sera, walima bana man'a sòò.

filèlikè yàò la, ba b'a dòn, waati min na den bolo bè ci, walasa a ka kisi kulekufè ma, fasaja bana ma, ani sensabana ma (ni dów ko mulukuli bana), ni nyòninsan ma.

filèlikè yàò la, denmisènw ka banaw faamashyèn bè dòn. u fura bè kè a tuma na.



benyérin ka
n'i'p'a fé, den
fililike yóro la
m, n'a dabb
fililike yóro la
kulekure ma,
ni nyónin m
fililike yóro la
tuma na.

dògòròso fililike kera sababu nyuman ye



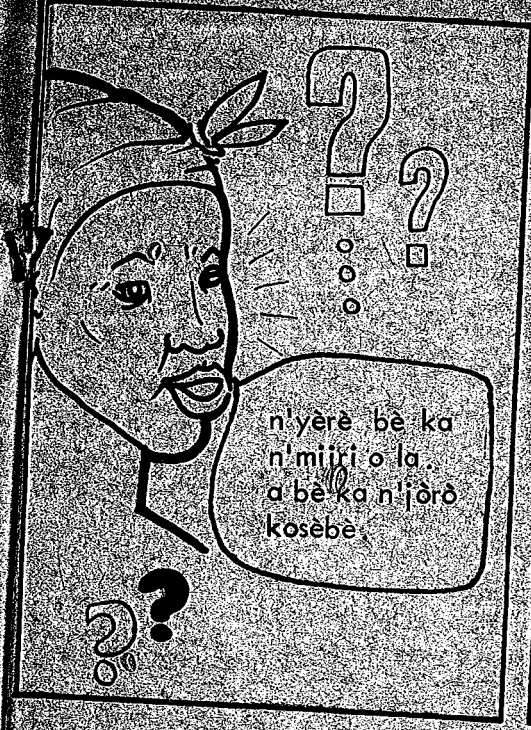

n'yerè bè ka
n'niiri o la,
a bè ka n'jòrò
kosebe.

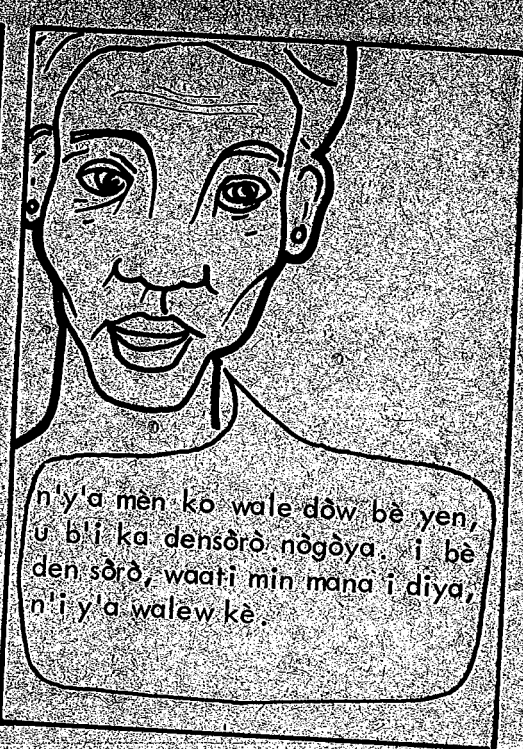

n'y'a mèn ko wale dōw bè yen,
u b'ì ka densòrò nōgōya. i bè
den sòrò, waati min mana i diya,
n'j'ya walew kè.

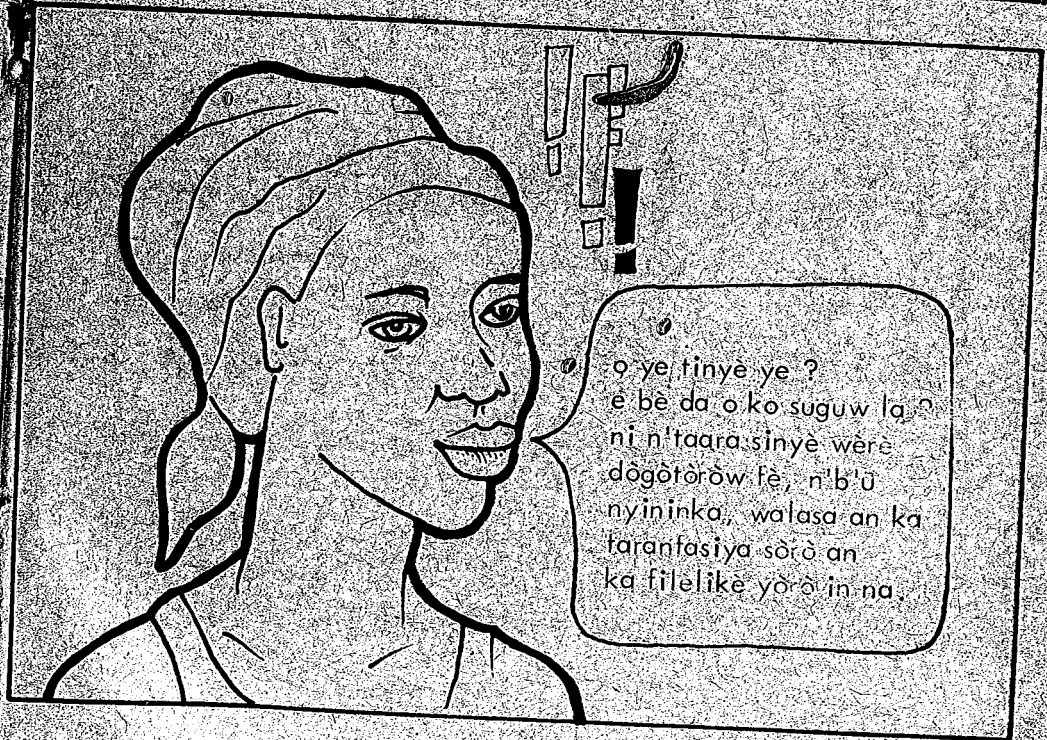

o ye, finye ye?
è bè da o ko suguw la,
ni n'taara sinye wèrè
dōgòròw fè, n'b'u
nyininka,, walasa an ka
taranfasiya sòrò an
ka filelike yorò in na.



filèlikè yòrò taali ye baara ye.
bari, a yòrò ka jan an ka dugu
la. n'o tè, n'yèrè tun bè taa
nyininkali dòw kè.

mògò ka hère bè yòrò min,
o tè janya i ma... n'a
filèlikè yòrò dò tun bè anw
fè yan, wajibi tè an ka yen
sègèrè, n'an bè hère nò fè.



o kòni don. n'y'a mèn
k'a yòrò in dilaler...
b'a sòrò, nafolo caman
taara nin da fè. jòn
wèrè ye nin dakabana
baara kè dè ?

n'ye min mèn, dugu in mògòw
de y'a dògòtòròso in jò. u ye
koperatiwu dila u ka dugu kònò.
nafa min sòròla koperatiwu fè,
o wari de kèra ka baaraba in kè.
an bèe bè ka bò
u ka koperatiwu nun ma.

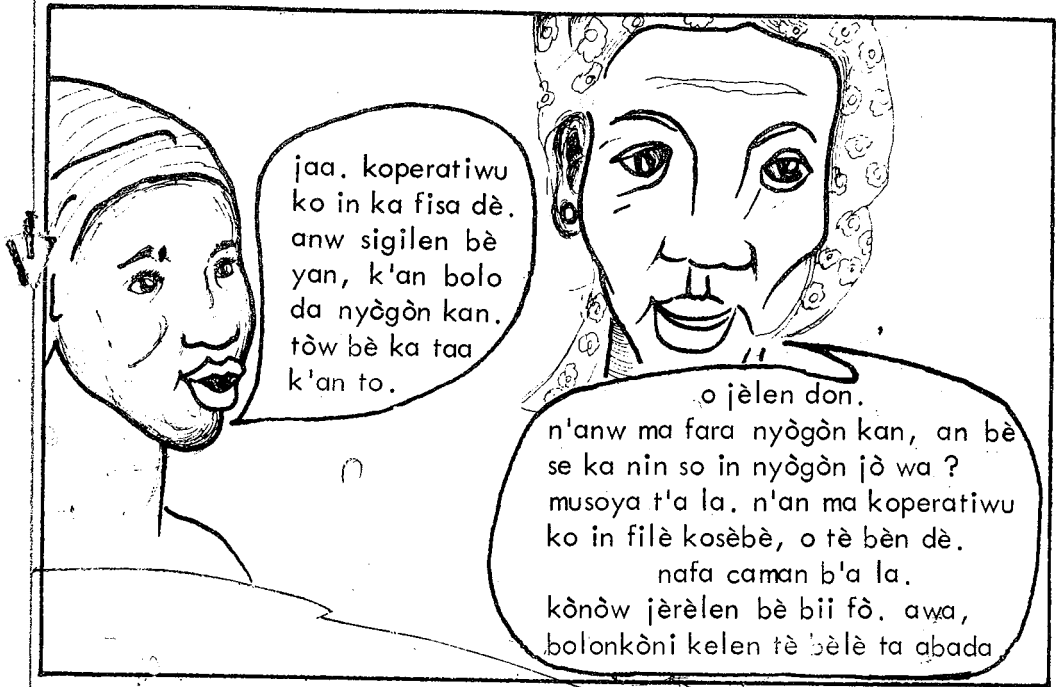

anw ye baro min mèn koperatiwu kan, o ye tɪnyè lakika ye.

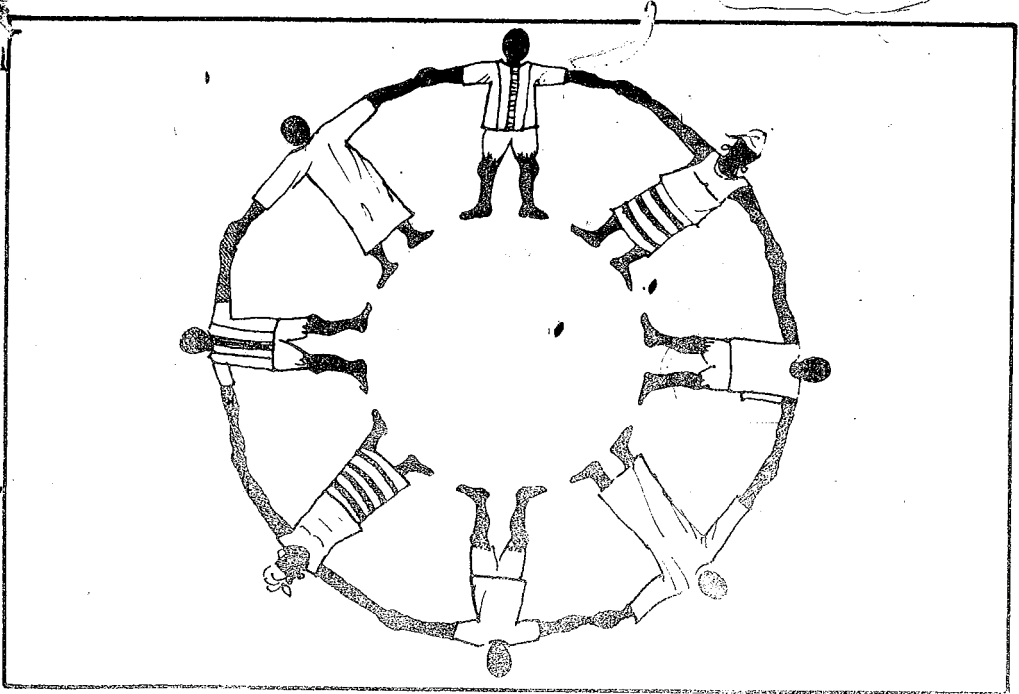

koperatiwudènw bè nyògòn bolo minè ten, ka koperatiwu lakana. aw kana to, naafigiw ka don aw ni nyògòn cè.

koperatiwu baara mana se,
koperatiwudenw bée bée wuli k'a baara in kè ni matarafa ye.

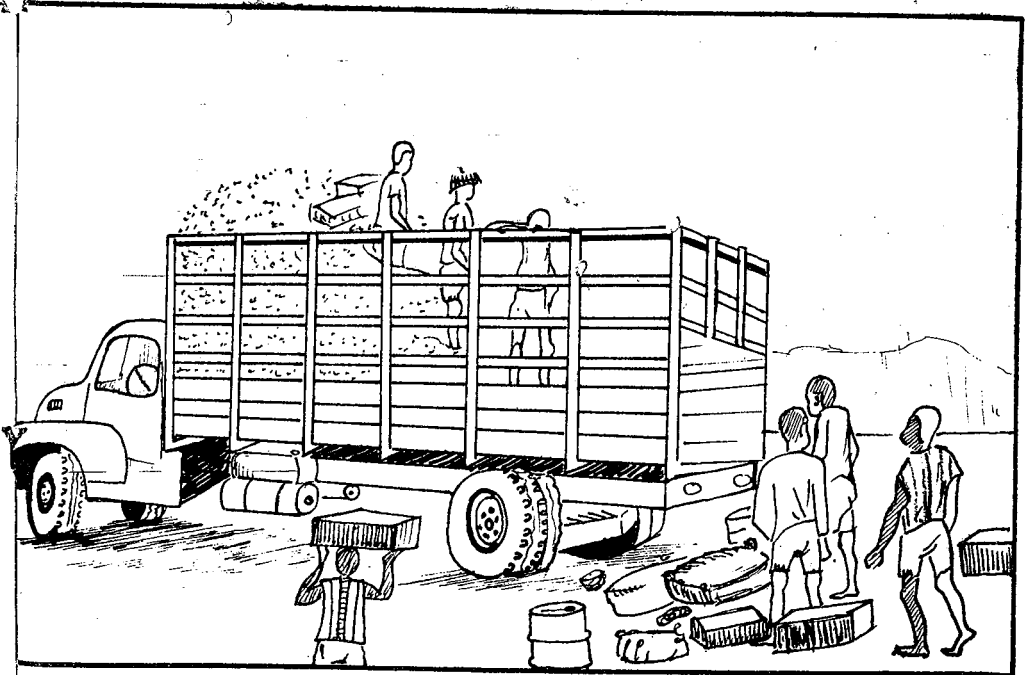
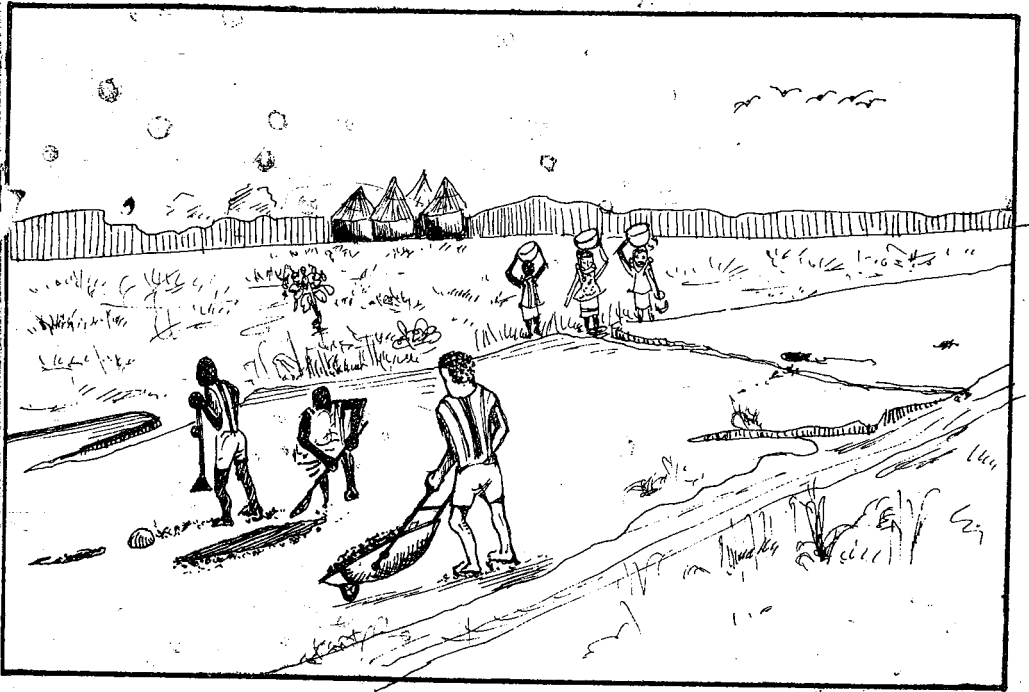

nin gafe in sèbèna sedu kònè fè,
koperatiwu balikukalan nyèmògò don.

a nyègèn w kèra amadu sanògò fè,
mali balikukalan oba nyègènkèla dò don.