

12004

# Koorisene baarada

baara  
kalan  
ka  
nyesin  
balikukalan  
telimanw  
ma



Nin gafe in ɲesinnen don balikukalan teliman ma, minnu be ke tile-  
ma fe kɔɔri sɛnɛ baarada yɔɔ dɔw la.

O kalan ninnu delila ka ke dɔgɔkun segin kɔnɔ :

- dɔgɔkun naani de be ke ka kalandenw dege kalanje la, ani sɛbɛnni ni jate.
- dɔgɔkun fila be ke ka dɔgɔkun naani ninnu ka baara dafa, ka kalandenw ka dɔnniya sinsin.
- dɔgɔkun fila be ke ka kalandenw dege baara dama dɔw la.

O dɔgɔkun fila ninnu be ke ka kalandenw dege baara minnu na,  
gafe in ka kuma ɲesinnen don o baara kalan cogo de ma.

O cogo file nin ye :

- karamɔgɔ be kalanden dɔ bila ka gafe nin ka kumaw kalan ka landen tɔ bɛɛ ɲɛ na.
- n'o kɛra, karamɔgɔ be ɲininkali ke, k'a dɔn ni ɲɛfoli bɛɛ faa muyara kɔɲuman kalandenw fe.
- ɲɛfoli mana faamuya ka ban, degeli be ke :

tɔn ka sɛbɛn minnu be kofɔ gafe nin kɔnɔ, olu lafa cogo be jira kalandenw na :

karamɔgɔ ni kalandenw bɛɛ be ɲɛ ka o sɛbɛn lafa walanba la folɔ fo bɛɛ k'a cogo faamuya.

O kɔ fe, sɛbɛn be di kalanden kelen kelen ma, bɛɛ k'i ta lafa ka ɲɛ.

Sɛbɛn lafa be ke ka tali ke tɔn dɔw ka walew la, i n'a fɔ baliku kalan be ke dugu min kɔnɔ, o dugutɔn ; walima, kalandenw bɔra dugu minnu na, o dugutɔnw.

fɛn o fɛn be kofɔ gafe nin kɔnɔ, ni degeli ka kan ke o la, i n'a fɔ jatemine mansin, basikili, foro suma, bagan furakeli, an'a ɲɔgɔnnaw, karamɔgɔ be fɛɛɛ tige, walasa o fɛn ninnu cogo ka se ka jira kalandenw na, bɛɛ ka se k'i dege o la.

Baara minnu be kofa gafe nin kana, olu file nin ye :

### Balikukalan

1. balikukalan dugu kana
2. kunnafoni dama daw

№ 3, fo № 11

№ 4, fo № 7  
№ 8, fo № 11

### Juru ta - juru kani

1. minenw nini cogo
2. minenw nali dugu kana
3. mangasa baara
4. tilali
5. juru kani

№ 13, fo № 24

№ 14 ani № 15  
№ 16 ani № 17  
№ 16 ani № 17  
№ 18, fo № 23  
№ 24

### Soro yiriwali

1. foro suma
2. tere furakeli
3. kalan foro
4. cikeda kunnafoni seben

№ 25, fo № 32

№ 26 ani № 27  
№ 28, fo № 30  
№ 31  
№ 32

### Sannifeere

1. sannifeere ke cogo
2. koori numan soro cogo
3. sannifeere laben cogo
4. sannifeere jekulu
5. koori taali izini la
6. koori wari sarali

№ 33, fo № 53

№ 34  
№ 35 ani № 36  
№ 37, fo № 39  
№ 40, fo № 49  
№ 50  
№ 51, fo № 53

### San wari jate ba siraw

1. kesu nefoli seben
2. ninan tona jatemine cogo
3. warije yelma cogo ninan
4. san nata baaraw
5. jatemine mansin

№ 55 fo № 67

№ 56 ani № 57  
№ 58 ani № 59  
№ 60, fo № 62  
№ 63  
№ 64, fo № 67

# balikukalan

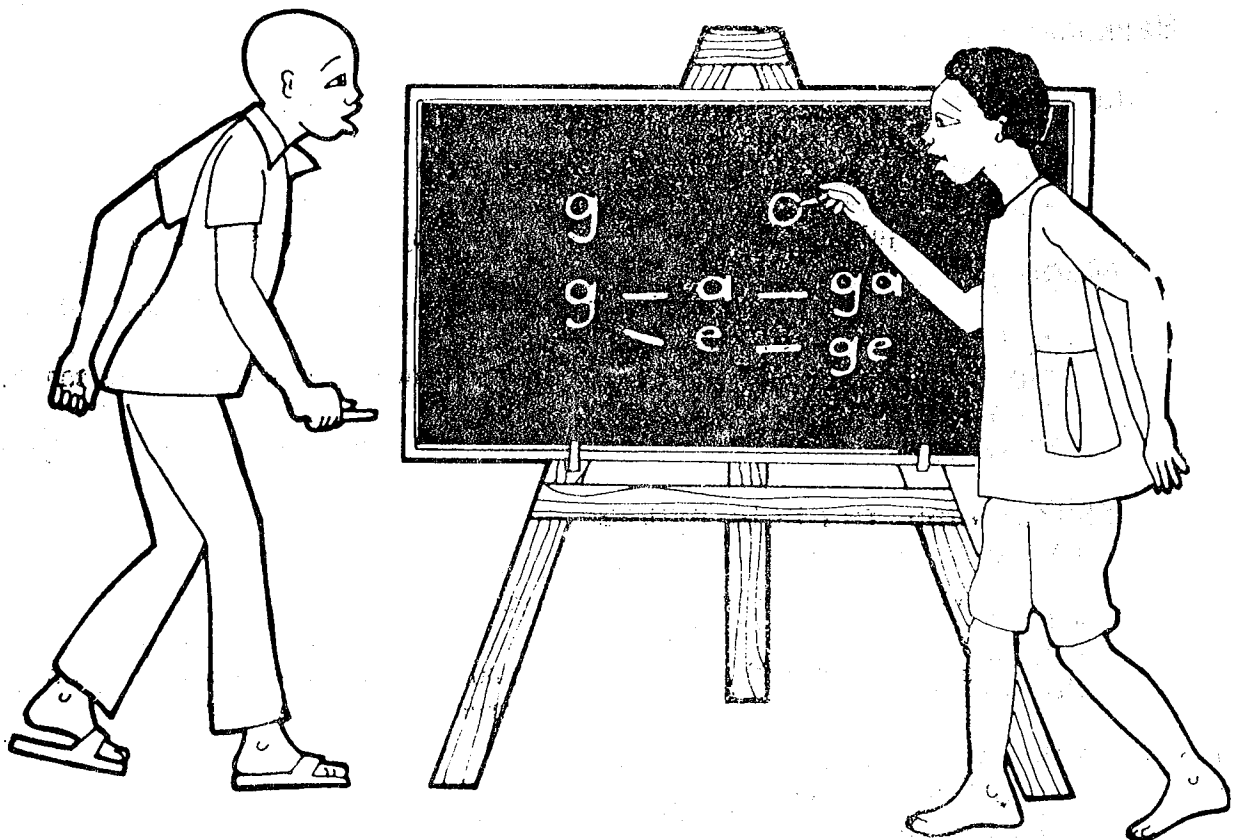

# 1. Balikukalan dugu kono

## Balikukalan kun

An ka dugu kono, seneke yoro la, mogo caman be yen, minnu te se kalan na : u ma tubabu kalan ke, u ma larabu kalan ke, wa min nu yere ye donin ke nin do la kelen na, olu ma taa ne kosobe, u m'a faamuya ten walasa ka se ka tow kalan, walima ka baara were ke n'u ka donniya ye.

Balikukalan min be ke i yere wolo kan na, o be nogo ya i ma, a b'i dege kalanni, ani sebenni, ani jatemine cogo bee la.

Kalandenw ye balikuw ye, karamogo fana ye baliku ye.

A kun ye walasa i be se

- k'i ka fotaw seben, k'a sebennen kalan, ka jatemine ke
- o kofe, k'i janto dugu ton na, k'a lakana juru don, sannifeere, minenw jinini sira fe.
- ka donniya kura soro sene, keneya ni bagan mara siratige la.

## Balikukalandenw

**Jon ni jon ka kan ka kalan dugu kono ?**

- a folofolo be ke dugu korenabolaw ye
- a filanan, dugu mogo bee : ce ani muso

**Mogo joli ka kan ka kalan folofolo dugu korenao kama ?**

- fo ka se mogo mugan ngon ma, minnu joyoro be ton kono, ka tila cikeda ni ngon ce.
- a ka kan ka ke mogo basigilenw ye, minnu si b'a ta san mugan, fo ka yelen.

## Balikukalan taabolo puman

fo k'a ke dugu mogo bee haminanko ye.

ka mogo kelen walima mogo fila sugandi, minnu ka baara nesinnen don kalan sinsinin ma : u be ke kalan korenabolaw ye dugu kono.

kalan korenabolaw ka baara :

- u b'u jija, kalanso ka jo, ka minenw bila a kono.
- ka kalandenw nesin kalan ma.
- ka kalandenw seben : mogo 20 ngon san o san, hakaja du o du kalanden kelen.
- k'u janto kalandenw ni karamogo nali cogo la kalanso kono.
- ka kalankeminenw jini, i n'a fo : gafew, lakere, petroli, ani fen werew,
- ka ben ke kalan ke don ani kalan ke waati kan.

## Balikukalan karamoƙo

### Balikukalan karamoƙo sugandi cogo

- a ka ke dugu den ye,
- a ka ke moƙo kalannen ye,
- a kana ke yaala moƙo ye,
- a ka ke moƙo laadiri ye, kunnakenema, hakili sigilen.

### Karamoƙo ka baara

- a be kalandenw kalan.
- kalanso n'a kono minen bee b'a ka mara la.
- a be kalanso nali seben laben.
- a be balikukalan kuntigi deme kiimeli la.
- a be kalan kunkow nefa kalan penabolaw ye.

### Kalanso minenw

- gafew : kalanje ni sebenni, jate, karamoƙo demenan.
- sebennikelanw : lakere, kerayon ni bikiw.
- walanba, walandenninw, kayew.
- erigili jaamanjan ni erigili surunmanninw.
- lanpanw.
- karamoƙo sigilan ni tabali.
- gafe mara kesu.

### Kalanso jocogo

- a be ke, i n'a fo ja b'a jira cogo min
- jajan : metera 8. josurun : metera 5.
  - kundama : metera 3 (biriki sira 12 fo 20).
  - biriki dalen 1200, walima biriki banamini 2100.
  - toli 50.
  - da kelen ni finetiri 5.

### Kalan kecogo

a kera kalanje degeli ye, walima sebenni, walima jate, karamoƙo b'i sinsin karamoƙo demenan kan, ka kalandenw dege, karamoƙo demenan b'a fo k'a pereperelatige cogo min.

Karamoƙo k'i jayoro don, n'o ye ka kalandenw deme,

- u yere ka se ka donniya jini gafe kono,
- u yere ka se ka donniya soro u yere ma.

# Kalanso ja

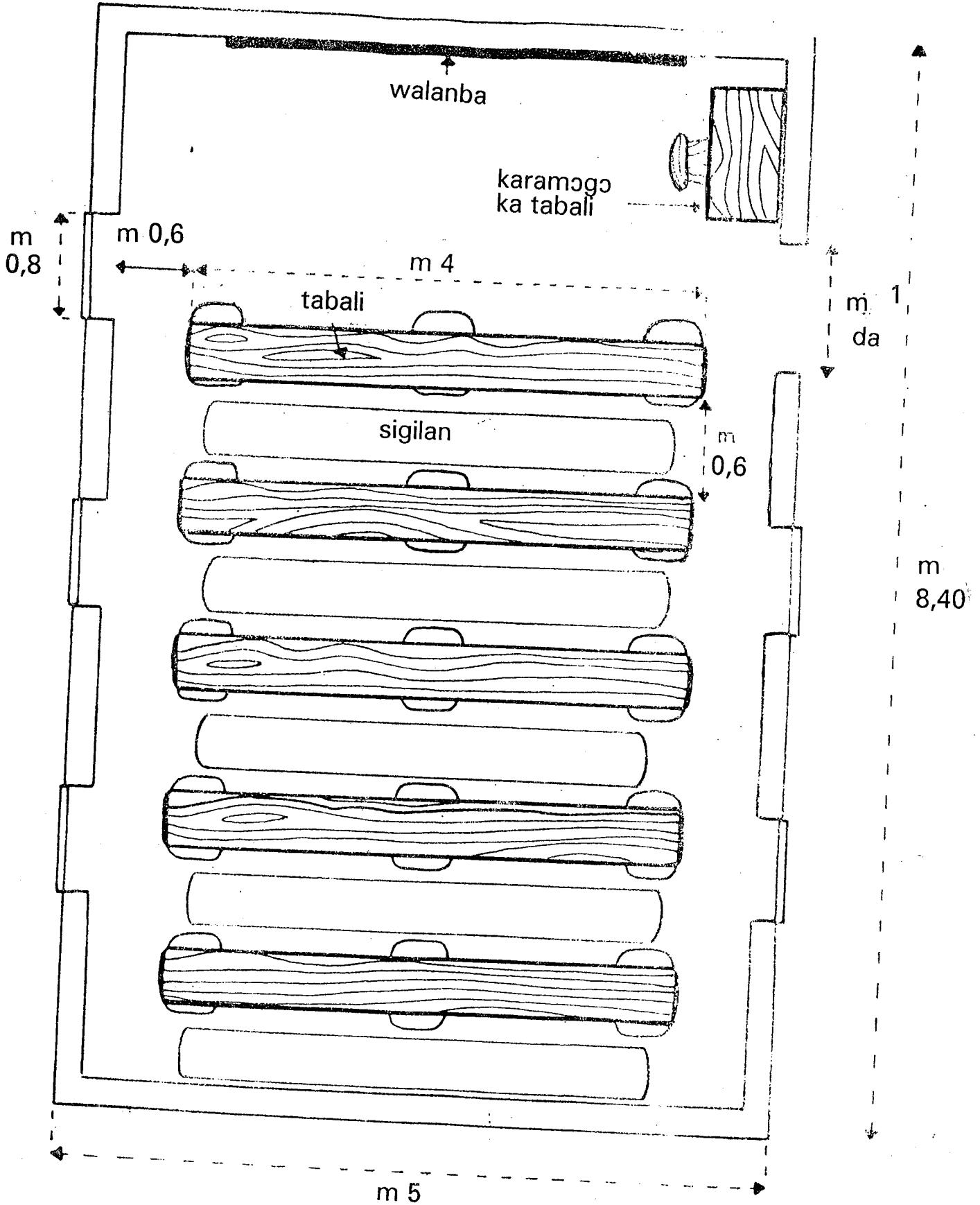

**Kalanso nali kaye**

Kunnafoƚi minnu ka kan ka di kalanden kan, olu be seben kalanso togoƚe kaye ne folo kan, i n'a fo : togo ni jamu, si hake, ce wali muso, a nimoƚo n'a jogyo cikeda la.

Kalanso togoƚe kaye ne toƚ be ke ka kalandenw nali seben don o don.

Nalen be taamashyen ni + ye. Nabali be taamashyen ni o ye. Naba liya kun be se ka seben kunnafoƚi yoro la.

Nimo- ro	Togo ni jamu	san 198..., ..... kalo, tile 1 fo 15.															
		1	2	3	4	5	6	7	8	9	10	11	12	13	14	15	mumε
1	Adama Jara																
2	Baru Ture																
3	Seku Kone																
4	Isa Jalo																
5	Isa Jalo																
6	Fanta Jalo																
7	Madi Tarawele																
8	Burahima Ture																
9	Adama Jalo																
10	Mohamadi Jalo																
Kalanje ne kalannen jate ne kalannen																	
Kunnafoƚiw : .																	



## 2. Kunnaƴoni dama dɔw

Mɔgo mana balikukalan gafe ninnu kalan ka ban (n'o ye "kaalanje ni seƴenni" ye, ani "jate"), i be se ka kumaw seƴen, k'u kalan, ani ka jate-mine ke, i n'a fo kafoli, doƴoli, sigiyɔromali ni tilali.

Gafe ninnu kɔno, neƴoli te caya kosebe, walasa kalan ka nɔgoya kalandenw bolo :

- jate kecogo be fo k'a soro a ma janya kalanden ka jate ke cogo koro la, n'o ye dala jate ye.
- kalanje ni seƴenni be kalan ka tali ke kalandenw ka folen korow la, i n'a fo, kuma be fo cogo min, k'a seƴen ten, k'a kalan ten.

Kunnaƴoni do werew be se ka di jatemine ke cogo ani kalanje ni seƴenni kecogo la, minnu b'a to karamogo ka se ka faamuyali soro o la. O faamuyali in be se ka ke sababu ye kalandenw dege ko be nɔgoya a bolo.

O kunnaƴoni dɔw file nin ye.

### Bamanankan sigini

A seƴenna "kalanje ni seƴenni" gafe kɔno, a ne 47 la, ko bamanankan siginiden suguya ye fila ye.

I komin folofolo bamanankan tun te seƴen, togo ma soro o siginiden suguya fila la an benbaw fe. Nka, kosa in na, mogo dɔw y'i miiri o kore in na. U ye min soro, olu file nin ye :

- siginiden suguya folo, n'o ye a, e, ε, i, o, ɔ, u, u y'olu wele ko "dafalen". O koro ye ko o siginidenw dafalen be u yere ma. Bawo, koro b'u la, hali n'u be u dan ma.
- ni "n" seƴenna o dafalen kinin fe, u b'o wele ko "nunnadafalen". Bawo, a foto, a be ke, i n'a fo i be kuma i nun na.
- n'o dafalen seƴenna siƴe fila, u b'o wele ko "dafalen samalen". Bawo, a foto, a be sama.
- siginiden suguya filanan, n'o ye b, c, d, f, g, h, j, k, l, m, n, ɲ, ɲ, p, r, s, sh, t, w, y, z, u b'ou wele ko "dafata". Bawo, u te se ka kalan u dan ma kumaseƴen kɔno ni dafalen ma ke k'u dafa.
- ni "n" seƴenna o siginiden numan fe, u b'o wele ko "nunnadafata". Bawo, a foto, a be ke, i n'a fo i be kuma i nun na.

## Kanɓe ni dajɓe

### Kanɓe

Dafalen kelen mana ke, o be se ka kalan, i n'a fo "u". Dafalen mana ke dafata kininfe, o fila be kalan ka ke kelen ye, i n'a fo "nu".

O fen ninnu minnu be kalan kelen ye, olu be wele ko "kanɓe"

### Dajɓe

Kanɓe de be tugu jɓɓon na ka kuma. Nka, n'i be kuma, i be kuma minnu fo, koro de b'olu la.

O kuma kelen kelen, ni koro b'a la, u b'o wele ko "dajɓe".

N'i y'a laje, i n'a ye ko

- dajɓe dow ye kanɓe kelen ye, i n'a fo "ba", "taa", "du", "u".
- dajɓe dow ye kanɓe fila ye, i n'a fo "bana", "dɔɔɔ".
- dow ye kanɓe saba ye, i n'a fo "jabibi".
- dow ye kanɓe naani ye, i n'a fo "niwakini".
- dow yere be teme o kan, i n'a fo "fitirinwaleya".

### Kuma sebencogo

N'i be sebenni ke, i k'i janto a la tuma bee ko

- kanɓe minnu be tugu jɓɓon na ka ke dajɓe kelen ye, olu ka kan ka noro jɓɓon na, sebenni keto.
- o n'a fo, n'i b'a fe ka "misiri" tɔgo seben, i kan'a seben abada ko "mi si ri". Nka, i ka kanɓe saba ninnu seben k'u noro jɓɓon na : "misiri".
- dajɓe ni jɓɓon ce sa, i be yoro sebenbali do to, k'u bo jɓɓon na kopuman, i n'a fo : "Sidiki donna misiri koro".

N'i y'i janto kuma fila in na, i mana min seben, o be faamuya joona a kalanbaga fe.

**Jatedenw sigicogo jateso kɔnɔ**

I mana jate sɛbɛn cogo dɔn jateso kɔnɔ, o bɛ kɛ sababu yɛ ka da dafabaliw ni foro kɛnɛ jateminɛ cogow faamuyali nɔgɔya i bolo.

**Jatesow :**

Miliyɔn sɛrɛ			baa sɛrɛ			Baa nɔna sɛrɛ		
kɛmɛ w ka so	biw ka so	kelenw ka so	kɛmɛw ka so	biw ka so	kelenw ka so	kɛmɛw ka so	biw ka so	kelenw ka so

Jateso in kɔnɔ, i bɛ miliyɔn sɛrɛw ni baa sɛrɛw ni baa nɔna sɛrɛw yɛ ; o y'a sɛrɛba saba yɛ.  
baa sɛrɛ bɛ cɛmancɛ la, miliyɔn sɛrɛ bɛ numan fɛ, baa nɔna sɛrɛ bɛ kininfɛ.

So saba bɛ sɛrɛ in kelen kelen kɔnɔ : o yɛ kelenw, biw, ani kɛmɛw ka so yɛ.

**Baara kɛcogo ni sɛbɛn in yɛ**

Jateden kelen kelen bɛ sigi a ka so kɔnɔ, o yɛrɛ faamuya ka teli ni mɔgɔw bɛ kuma.

N'i bɛ jatedenw kalan jateso kɔnɔ, i b'i kɔlɔsi "ani" ni" fɔ yɔrɔw la.

- "ani" bɛ fɔ n'i bɛ bɔ sɛrɛ dɔ kɔnɔ,ka na dɔ wɛrɛ kɔnɔ.
- "ni" bɛ fɔ n'i bɛ jateden kalan so kɔnɔ, k'a sɔrɔ i ma bɔ sɛrɛ kɔnɔ.

misali : an ka 2 585 671 kalan

miliyɔn fila ani baa kɛmɛ duuru ni ba bi seegin wɔrɔrɔ ni duuru ani kɛmɛ wɔrɔrɔ ni bi wolonwula ni kelen.

## Jateminε

### 1. kafoli

$$\begin{array}{r} 21 \\ + 24 \\ \hline = 45 \end{array}$$

walima  $21 + 24 = 45$

a kalan cogo : mugan ni kelen ani mugan ni naani, o ye bi naani ni duuru ye.

kafoli yɔrow : 21 ni 24 ye kafotaw ye.

45 ye sɔɔlen ye.

+ ye kafoli taamasinyɛn ye. A bε kalan "ani" walima "n"

= ye kɛɛlan ye. A bε kalan : "0 ye... ye".

### 2. Dɔɔɔli

$$\begin{array}{r} 5 \\ - 3 \\ \hline = 2 \end{array}$$

walima  $5 - 3 = 2$

a kalan cogo : 3 ye bɔta ye.

2 ye to ye.

- ye dɔɔɔli taamasinyɛn ye. A bε kalan "bɔlen".

### 3. Sigiyɔɔmali

$$\begin{array}{r} 4 \\ \times 2 \\ \hline = 8 \end{array}$$

walima  $4 \times 2 = 8$

a kalan cogo : naani sigiyɔɔma fila ye segin ye.

sigiyɔɔmali yɔrow :

4 ye sigiyɔɔmata ye

2 ye sigiyɔɔmalilan ye.

8 ye sigiyɔɔmalan ye.

x ye sigiyɔɔmali taamasinyɛn ye. A bε kalan "sigiyɔɔma".

### 4. Tilali

$$\begin{array}{r} 14 \\ 2 \overline{) 3} \\ \hline = 4 \end{array}$$

walima  $14 : 3 = 4$

a kalan cogo : tan ni naani tilalen saba ye, o ye naani ye ; a to ye fila ye.

tilali yɔrow : 14 ye tilata ye

3 ye tilalilan ye.

4 ye niyɔɔ ye.

2 ye to ye.

— walima : ye tilali taamasinyɛn ye. a bε kalan "tilalen"

| =

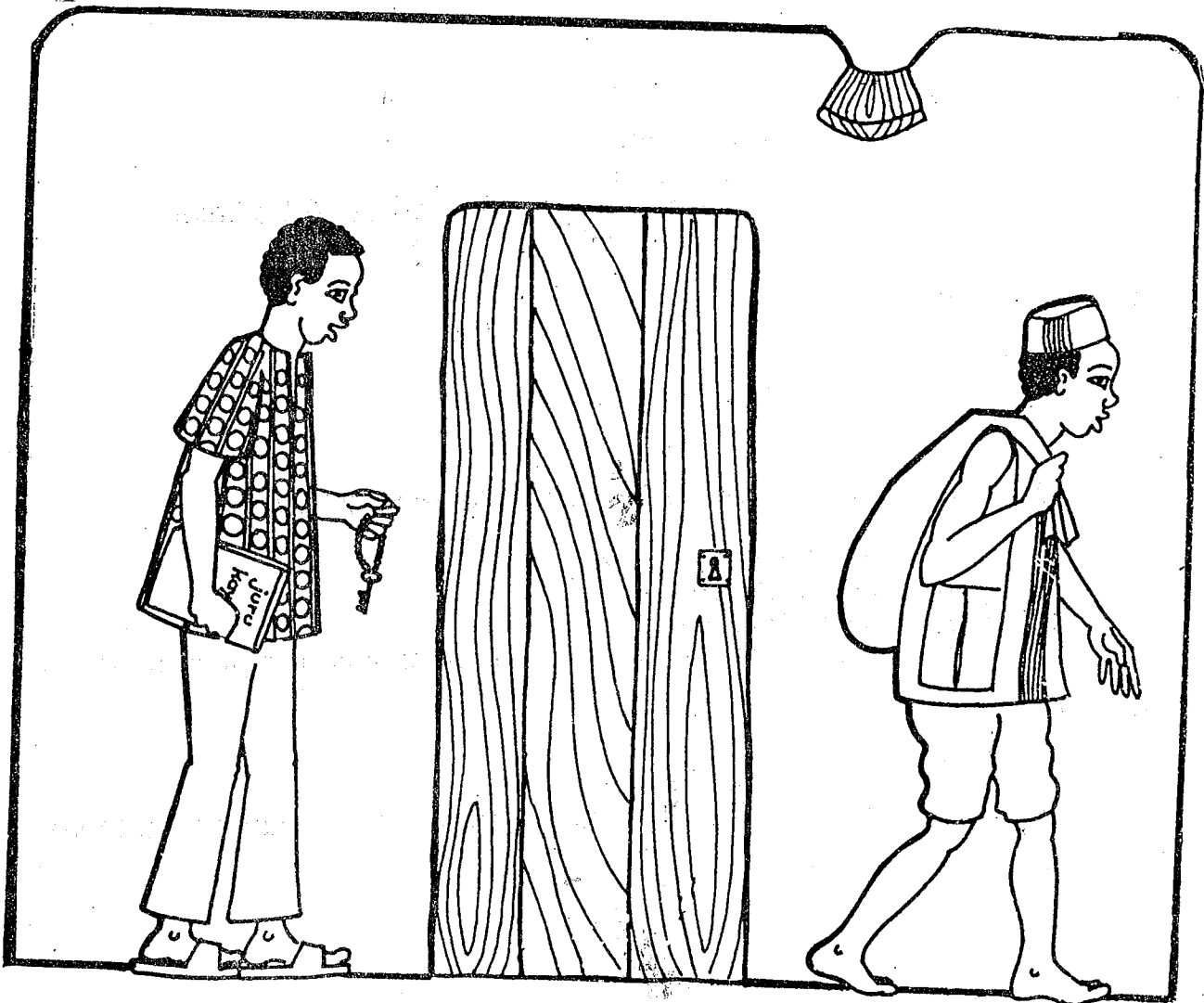

# Juru ta - juru kani

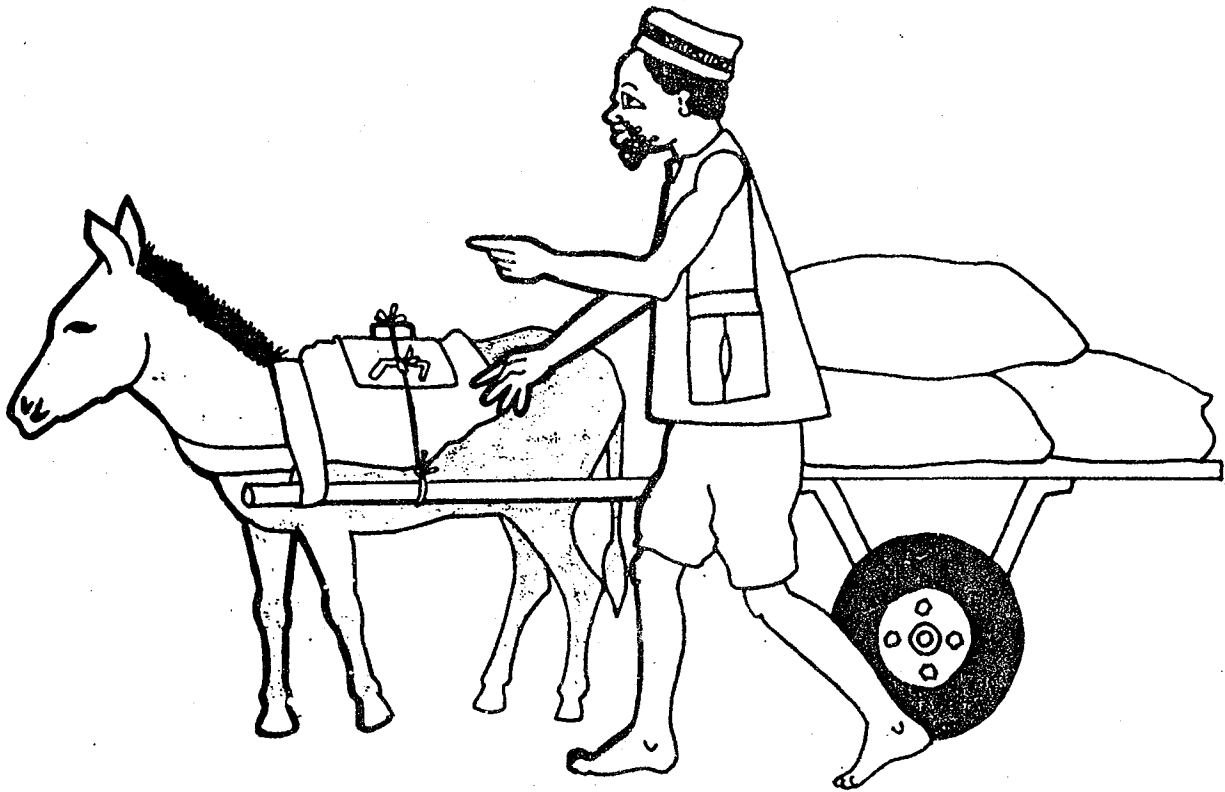

## 1. Minenw pinicogo

### Minen minnu be se ka pini

- Cikeda be samiyɛ jɛsigi ni mun ye ?      suman siw, nɔgɔw, furaw,  
baarakɛminɛnw.  
suman siw ni nɔgɔw ni furaw be pini san o san. Baarakɛminɛnw  
be mago jɛ san caman kɔnɔ.
- Cikeda b'i sinsin mun ni mun kan k'a magoɲɛminɛnw pini ?  
a b'i hakili da yɔrɔ dama dɔw kan :  
baarakɛlaw hake ni mago balotaw hake,  
kene senɛta mume,  
bolo kɔrɔ minɛnw ni bolo kɔrɔ balo,  
san tɛmɛnɛnw ka sɔrɔ  
juru talen saracogo.

duguyiriwatɔn cikeda kelen kelen bɛɛ ka kan ka nin wale ninnu  
bɛɛ labato, walasa :

- tɔn k'a ka minɛnɲinisɛbɛn labɛn,
- tɔn ka se k'a ka minɛn pinitaw si dɔn,
- tɔnden si ka juru kana caya a ka sɔrɔ ma.
- duguyiriwatɔnden bɛɛ be wele tɔnsigi kɛrɛnkɛrɛnnen na,  
ka bɛɛ ka minɛn ɲinɛnw sɛgɛsɛgɛ, walasa k'a dɔn ko sa  
riya minnu sigira, u y'u labato,  
ka kunnafoni di tɔnden bɛɛ ma minɛnw sɔngɔ kan, juru  
sariyaw kan, ani juru jɛbilaw sarata la.  
ka kɔrɔri sɛnɛ lakɔliden ladɔnɲiya baara kelenw na,  
walasa a ka laadili kan di, walima ka filiw latilen.  
K'a pereperelatige bɛɛ ye ko nɔgɔni bagaji juru man  
kan ka san si.

### Minen be pini cogo di ?

- N'an b'an ka dugu magoɲɛminɛnw pini, an b'a kɛ k'an hakili to  
minɛnw na, minnu ye san si,
- jɛkulu be sigi, jɛkulu min ka baara be jɛsin juru kɔɲɛw ma :  
ka juru jɛbilaw sarali kɔlɔsi u di tuma na sɛbɛnnikɛla ma,  
ka sɛgɛsɛgɛli kɛ cikɛla bɛɛ ka minɛn ɲinɛn kan, k'a da u kelen  
kelenna se kan,  
a b'i jan to kɔsɛbɛ cikɛdaw la, cikɛda minnu ye gɛlɛya sɔrɔ u  
ka san tɛmɛnɛnw juru ko la.
- minɛnɲinisɛbɛn be lafa,
- juru jɛbila ni minɛnɲinisɛbɛn lafalɛn be laɛsɛ lakɔliden kuntigi ma.

Karamoƙo be misalikemine jini seƙen lafali kan nin cogo in na :

kalanden kelen kelenna bee b'i ka minen pininenw fa,  
do b'o seƙen walanba kan.

u be je ka bee ta segelege, ka filiw latilen.

kalandenw be soro ka minenjini seƙen lafa u yere ye.

### Minenjini seƙen

Dugu ..... lakoliden sigiyoro ..... lakoliden kuntigi ..... mara kuntigi .....				
Koori kene ..... kaba kene ..... nogoƙin bore hake..... nogoje bore hake ..... furaji litiri 5 ..... binnagasi fura (kooari) ..... binnagasi fura (kaba)..... sijolan ..... bagan balo ..... misi kogo ..... tere fura .....		dabanana dabafin dannike mansin ciwara ponpe pilima wotoro ..... .....	san 1 juru	san 3 juru
kalo ..... tile ..... san ..... ton kuntigi bolono .....				

Segin be ke minenjini seƙen kan

- ka minen kafo jagon kan, minnu ye suguya kelen ye,
- ka jinini seƙen laben.



## 2. Minenw nali dugu kɔnɔ

### Ni mobili sera dugu kɔnɔ

- mobili bolila bɛ minensamaseben di dugu yiriwa tɔn ka lasigiden ma.
- minen nalen bɛɛ suguya kelen kelen bɛ jigin u dan ma.
- mangasatigi bɛ minenw dan mobilitigi jɛ na. A b'u hake sanga ni minen sama seben kɔnɔ ta ye.
- ni jatew ye jɔgɔn ta, a b'i bolonɔ bila seben in kan.
- ni dɔ y'a jɛ, walima ni tijenen yera minenw cɛ la, a b'o hake dantige seben in kan, ka sɔrɔ k'a bolonɔ bila seben kan, ka tila ka lakɔliden kuntigi ladɔnniya a la.
- tɔn ka lasigiden bɛ seben jɛman ta, ka bilenman segin mobilitigi ma.

### Mun na, sɛgɛsɛgɛli bɛ kɛ ?

- bolonɔ bilalen kɔ minensamaseben kan tɔn lasigiden fɛ, o b'a jira ko minenw kɛra tɔn ta ye, wa dugu ka kan k'u sara.
- a kun ye fana, ka se ka fiɛ kɔlɔsilenw fɔ joona minen samabagaw ye.
- k'a sɛmentiya ni minenw nalen ni pininen hake ye kelen ye.

## 3. Mangasa baara

Mun na, mangasatigiya ka kan ka di mɔgɔ kelen ma ?  
 minen nalen ninu ye nafolo de ye : mangasa konɔin ka sɔrɔ mɔgɔ kelen pe bolo, n'ale de bɛ pininka mangasa kɔjɛ bɛɛ la.

Kunnafoni bɛ sɔrɔ cogo di mangasa minenw donni n'u bɔli la ?

- minen suguya kelen o kelen n'a kunnafoni seben don.  
 nin yɔrɔ ninu b'u la : don, jɛfɔli, dontaw, bɔtaw, tɔ.
- mobili min nana ni minenw ye, ani seben min dara minenw kan, fɔ k'u nimɔrɔw sigi jɛfɔli yɔrɔ la dontaw la.
- bɔtaw yɔrɔ la, hake min bɔra tile kɔnɔ, o de bɛ seben.

### Mangasatigi ka baara

- ka mangasa kunnafonisebenw lafa,
- ka jɔ ni baara kɛcogo numan ye, minenw donni n'u bɔli waati la (dabaw, nɔgɔw, furaji, o n'a jɔgɔnnaw).
- ka jɔ ni mangasa yɛɛ ladonni ye (bili, da, kogo), walasa ka minenw tanga sanji ma.
- k'i jan to minenw bila cogo la. Ka bɔrɛw sogolon, k'a sɔrɔ u ma gun kogo la. Nɔgɔ ni furaji kana se jɔgɔn ma.

An ka minensamasɛben kɔnɔ fɛnw laɛ, k'an dege a kalancogo la :

kɔɔri sɛnɛ baarada (C.M.D.T.) sama cibaga : ..... minɛnw jigin yɔɔɔ : ..... (station expéditrice) (station destinataire) lasebaga tɔɔɔ (transporteur) : ..... <p style="text-align: center;"><b>Minensamasɛben nimɔɔ ....</b>  <b>(bordereau d'expédition N° ....)</b></p>				
hake (nombre)	siya (genre)	girinya (poids)	da (quantité)	minɛnw suguya (nature de la marchandise)
Cike don (expédié le) : ..... minɛn kofɔlɛn sɔɔɔli sɛmɛntiyara an fɛ (reçu la marchandise ci-dessus) minɛn tabaga (le destinataire) minɛn lasebaga (le transporteur) bolonɔ (signature)				

**Mangasa kunnafoniseben**

siya.....

don	ɲɛfɔli	don-taw	bɔ-taw	tɔ

Mangasa kunnafoniseben kelen kelen ka di kalanden bɛɛ ma.  
 baara bɛ kɛ ni sɛben in ye cogo di ?

## 4. Tilali

### Tilali be ke cogo di ?

- ka nogo ni furaji tila u don waati yere la, i n'a fo, furaji te tila k'a soro furakeli tuma ma se.
- ka cikeda bee wele tilali tuma na, walasa mangasatigi fana kana degun mogo makononi na seneke waati la.
- minenjiniseben be ta, ka cikelaw togo wele, k'o nefa.
- tilali kaye be ta, ka talen so lafa.

### Mun na, nin ke cogo in ka kan ka matarafa ?

- ka magone minenw tanga tineni ma (nogo, furaji...)
- dugu yiriwa ton ka tilali o tilali la, ton ka kan k'a hakili to seneke cogo numan matarafali la cikedaw fe.
- ka si dita kene ni foro kene sumanen ye.
- ka nogo dita bere ben kene dannen ma, k'a di k'a da danni waati kan ani foro ka sun soro kan.
- ka furaji di k'a da furakeli folo ke waati kan.

### Juruseben lafali

- segin be ke tilalikaye kan ka juruseben lafa.
- juru jate bo be ke ni minenw songo sebenw ye.
- cikela bee ka ka san juru hake be jate.
- jate bo be ke minen dilenw kan : suguya kelen o kelen ta be sigi a dan ma, ka da sorolen sanga ni san juru ye, walasa ka filiw latilen.
- nin sira ninu be boli ka san kelen juru seben ni san saba juru kaye bee lafa.
- an be ben fana ka cikeda kelen o kelen ka juruseben dilan. O be ke sababu ye ka faranfasiya di cikeda kelen kelen ma a ka juru kan, k'a nogo a bolo.
- sani jurukani waati ce, a wajibiyalen don, seben nenabola ka dugu ka san juru hake sanga cikelakoliden ta sebbenen ma.



..... bolofara ..... dugu yiriwatɔn ..... zeri

..... sekiteri .....



Ni-m-ɔ	Tɔg ni jamu	ga mɔgɔ daba hake	salon kɔori seneelen		ninan seneɛta		sarataw san kɔnɔ	Juru pini kunnafoni								
			taari	hake	sɔrɔ	taari		taari	hake	sugu-ya	nebila	san sarata				
	Juru tala mume															
	Duguyiriwatɔn tɔgɔla kuntigi sereketeri/warimarala															

sarata B.N.D.A. ye san kɔnɔ

a kera ..... kalo ..... tile..... san.....

B.N.D.A. bolofara nɛmɔgɔ

**Senekeminen dafa jurupiniseben**

..... bolofara ..... dugu yiriwatɔn ..... zeri  
 ..... sekiteri .....



Ni-ma-ro	Tɔg ni jamu	daba gana fin	dan-ni ke-lan	Mi n e n w				ponpe pilima c8	ponpe ba	bin fa-ga ponpe	nebila	Juru hake	san sarata
				wo-toro	hu-nin	kuru ci lan	ponpe pilima						
Juru tala mume													

Duguyiriwatɔn togola sarata B.N.D.A. ye san kɔɔ  
 kuntigi sereketeri/warimarala kɔɔri baarada a kera ..... tile..... san.....  
 zeri nɛmɔgo B.N.D.A. bolofara nɛmɔgo

.....



## Minenw songo

Hake	Koori si kilo 70 bore	ngofin kilo 50 bore	nggje kilo 50 bore	posoni litiri 5 gongon	binnagasi- fura (kaba) litiri 0,875 gongon	binnagasifu- ra (koori litiri 0,625 gongon	binnagasifu- ra (malo) litiri 5 gongon
1	50	1150	1050	850	228	275	2600
2	100	2300	2100	1700	456	550	5200
3	150	3450	3150	2550	684	825	7800
4	200	4600	4200	3400	912	1100	10400
5	250	5750	5250	4250	1140	1375	13000
6	300	6900	6300	5100	1368	1650	15600
7	350	8050	7350	5950	1596	1925	18200
8	400	9200	8400	6800	1824	2200	20800
9	450	10350	9450	7650	2052	2475	23400
10	500	11500	10500	8500	2280	2750	26000
20	1000	23000	21000	17000	4560	5500	52000
30	1500	34500	31500	25500	6840	8250	78000
40	2000	46000	42000	34000	9120	11000	104000
50	2500	57500	52500	42500	11400	13750	130000



## 5. Jurukani

### Juru saralen sɛben cogo

- sɛgin bɛ kɛ jurusɛben kan, ka jurumantigi tɔgo wele.
- nɔgɔfin mumɛ juru bɛ ladon fɔlɔ, walima nɔgɔfin ni nɔgɔjɛ lajɛlen, walima furaji dama ta : o bɛ ladon sanni fɔlɔ waati la, walima kaba feere tuma na.

kɔɔri bɛ kɛ hake saralenw na jurusɛben kan.

hake saralen bɛ sɛben sara ko fɔlɔ so kɔnɔ.

- juru sara ko fɔlɔ mumɛ bɛ jate :

ka magoɲɛminɛnw suguya bɛɛ jate bɔ a dan ma (a hake),

k'a kelen kelenna wari hake jate bɔ,

ka juru saralen hake jate.

### Juru kani tuma

Juru kani tuma ye sannifeere waati ye. Sɛnɛkɛla b'a ka wari soro tuma min na, o de y'a ka juru sara tuma ye.

### Juru sarabaliw

Tɔnsigi kɛrɛnkɛrɛnnen bɛ kɛ juru sarabaliw kan, k'a sɛgɛsɛgɛ k'a don, tɔn ka kan ka minnu dɛmɛ, ani a man kan ka minnu dɛmɛ.

A man kan ka minnu dɛmɛ, olu b'u kan di u ka juru sara cogo kan.

# Soro yiriwali

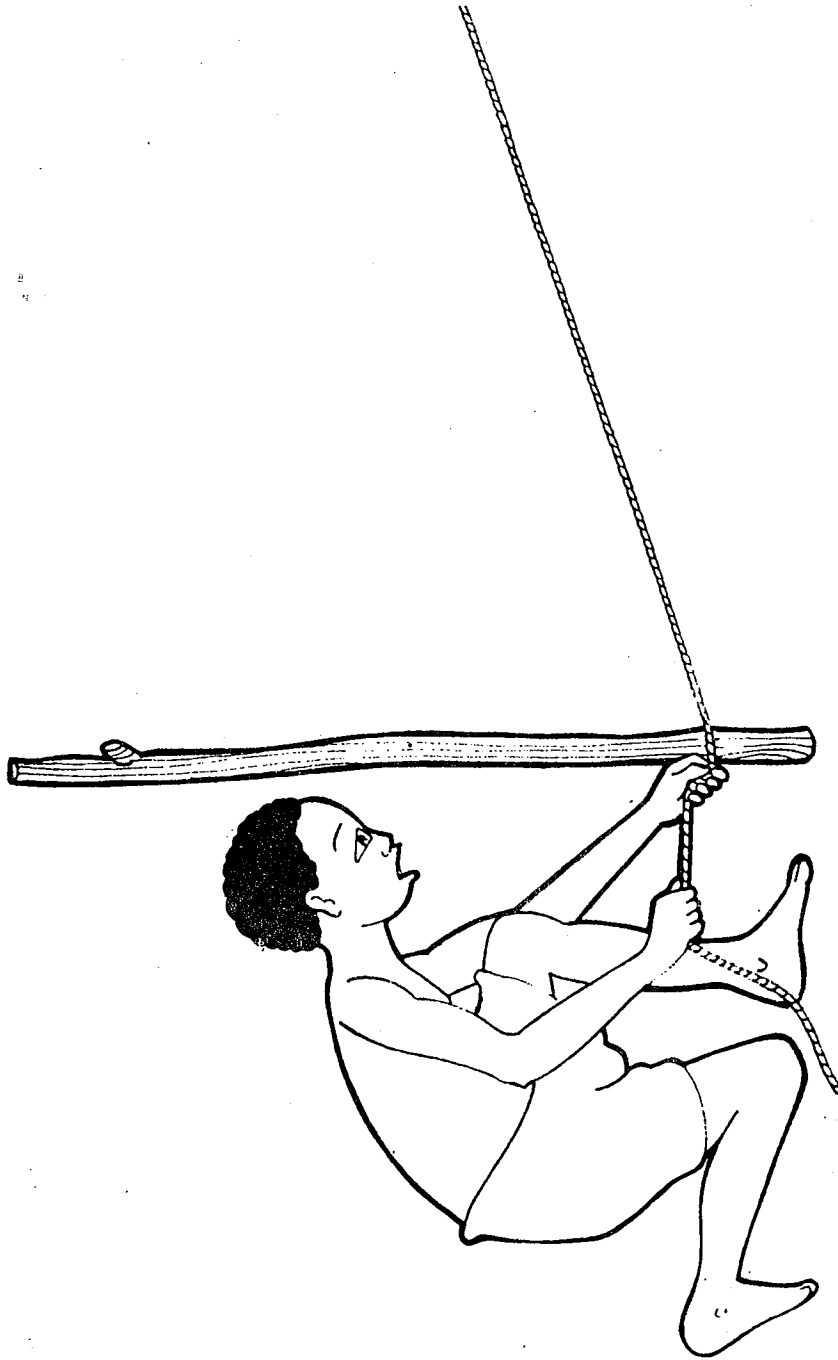

# 1. Forosuma

## Forosuma kun

Foro suma kun ye ka foro kere hake don.  
 folo, ciklakoliden tun b'o baara ke. Nka, sisan kere senetaw bonya  
 na. O temenen ko, dugu caman y'u yere ta. O de la, ciklakoliden be  
 kan ka dogoya, walasa cikela yere k'u ka foro suma ani k'u ka  
 magoje minen tataw jate don.

## Forosuma be ke ni mun ni mun ye ?

Bolo jan saba, bolo surun fila ; juru jan kelen ; daba, jele, ani bese.

## Forosuma be ke cogo di ?

### 1. Foro suma ke cogo folo ?

A baara kologirin ye seleke tilennen keli ye foro kere naani na. O ke  
 cogo file nin ye :

- a folo : i be foro kere folo danbo, ka bolo jan saba turu o la.  
 metere 50 de be bolow ni jogon ce ; awa, u saba be tilen jogon ma.
- a filanan : i be foro seleke tilennen folo sigi. N'i b'o ke, i be bolo su  
 runnin fila turu foro kere danbolen na bolo folo ko n'a ne. Furance ke  
 len de be u ni bolo folo ce ; awa, u ni bolo jan saba ninu be tilen  
 jogon ma.
- a sabanan : i be jurunin fila ta, minnu janya ye kelen ye. I be olu  
 kun siri ka nton ke a la. I b'u kunna ntonw don bolo surunninw na. I  
 be juruninw sama ka taa bolo folo kuntilenna na. U be jogon kunben  
 yoro min na, o ye bolo surunnin sabanan turu yoro ye.
- o bolonin kuntilenna ni foro kere folo danbolen bolow kuntilenna  
 kunben yoro be seleke tilennen jira n'o banna, i be bolo surunnin  
 folow fila bo.
- foro kere saba to be jini o cogo la.

### 2. Forosuma kecogo filanan

O fana baara kologirin in ye seleke tilennen keli ye foro kere naani  
 na.

- a folo : i be foro kere kelen danbo.
- filanan : sumalikelan min b'i bolo (metere, walima janya suma  
 likelan were), i b'o ne saba da kere danbolen na, k'a damine bolo  
 jan na foro seleke la, ka bolo surun kelen turu.
- sabanan : janya sumalikelan min b'i bolo, i b'o ne naani ta (ni  
 metere filanan fe, ka bolo surun kelen sigi bolo jan kuntilenna la.
- naaninan : i be sumalikelan ne duuru suma bolo surun fila ni  
 jogon ce. O be ben yoro min ma, ka bolo surun sigilen turu yen. O  
 mana ke, seleke dilannen ye seleke jolen ye.
- O be fo nin foro suma cogo la ko "3-4-5"

N'i t'a fe ka segin bolo turu kan san o san i ka foro la, i be se ka jiri sun  
 dow turu bolo ninu no na. O jiriw be se ka ke baganin ye, walima sebe  
 sun, bagafu, murafurajiri (ni dow b'a wele ko "ekalipitisi").

## 2. Kɔɔri numan sɔɔɔ cogo

### Kɔɔri suguya ye saba ye :

- Kɔɔri numan, n'u b'a fɔ "fɔlɔ". O ye kɔɔri jɛman pasipasi de ye, min bɔra kɔɔriden numan kɔɔgolen na. Ƴagapaga t'a la, i n'a fɔ furabulu jalan, kɔɔri kalaw, kɔɔri fara yere, walima bin. Ntumu de tɔ t'a la, belekise t'a la, kɔɔri bilenman t'a la.  
O kɔɔri ka kan ka lamara yɔɔɔ numan na yanni a feere don ce.
- Kɔɔri juguman ye kɔɔri ye, min tɛ jate numan fe : ale nɔgolen don, ntumu da tɔw ni kɔɔri kɔɔgobaliw b'a la.  
ale bɛ sɔɔɔ kɔɔri woloma tuma foro kɔɔɔ.
- Kɔɔri wolomabali, n'u b'a fɔ "filanan". O ye kɔɔri ye, i n'a fɔ a yere tɔɔɔ b'a fɔ cogo min, o ma woloma kabini foro kɔɔɔ. O ye kɔɔri numan ni kɔɔri juguman bɛɛ Ƴagaminen ye Ƴɔɔɔ na.

A fɔ kun tɛ ko kɔɔri numan de bɛ wari sɔɔɔ ka tɛmɛ tɔw kan. O la, a ka fisa an ka tɔn duguw ma, u ka kɔɔri numan caman feere.

### Kɔɔri numan bɛ sɔɔɔ cogo di ?

A fɔlɔ : ka i ka foro furake. ka keɲɛ ni cogoya fɔlen bɛɛ ye, ani k'a ke a waati la.

A filanan : ka kɔɔri bɔ Ƴoona, ka keɲɛ ni kɔɔri lakɔliden ka fɔlen bɛɛ ye, ani k'o lamara yɔɔɔ numan na.

Kɔɔri bɔcogo ka nɔɔɔn kosebɛ : kɔɔri bɔla bɛ minɛn fila ta, ka kɔɔri wolomali damine kabini foro kɔɔɔ : minɛn kelen ye kɔɔri numan minɛn ye, minɛn filanan ye kɔɔri juguman minɛn ye.  
A bɛ baara ke ten, fo ka kɔɔri bɔ ban

I n'a fɔ, sɛnekɛla caman b'a miiri ko kɔɔri Ƴɛ bɛ bɔ a dan tuma la, olu tɛ Ƴɔɔɔ na : "n ye n ka kɔɔri den Ƴoona", o tɛ kɔɔri ke fɔlɔ ye n'i ma a bɔ cogo ninnu matarafa.

## Fen dow be kɔri ne tije an bolo

An ka duguw kɔɔ, fen dow be ke sababu ye ka an ka kɔriw ne tije an bolo :

- ka dɔɔ ci ke kɔri bɔ la. An bɛɛ b'a don ko dɔɔɔ ka kow bɛɛ sɛsɛsɛgelen tɛ.
- kɔri dɔgɔdɔgɔnin bɔbaliya : an caman b'an jɔ, fo foro bɛɛ ka je ka ban, ka sɔɔ k'an labɛn a bɔli kama. Ni san nana ka kɔri fura jalan gosi, wajibi don, o ji ka an ka kɔri ne tije. O dun be ke sababu ye ka dɔ bɔ an ka kɔri dawula la.
- an jantobaliya denmisɛnw ni musow la kɔri bɔ tuma la.
- kɔri ladon cogo a bɔlen kɔ : an be kɔri mara yɔɔ dow la, minnu man ni : an be kɔri da dugukolo jalan na, fije tɛ don o yɔɔ la, a yɔɔw niginnen don. Hali n'i ka kɔri bɔ cogo bɛɛ jɛna, ni o mara ko ma jɛ, wajibi don, a jɛ be tije.

## Min ka kan ka ke

Dugu tɔn jɛmɔgɔw ka kan ka sɛnɛkelaw lasɔmi nin kow kan, minnu be ke sababu ye ka u ka kɔri ne tije, ka dɔ bɔ u ka sɔɔ la ; ka tɔn yɛɛ ka nafa dɔgɔya.

- aw minnu ye tɔn jɛmɔgɔw ye, aw de b'a jira dugu la mɔgɔ bɛɛ la ko dɔɔ be min ci bannen kɔ, k'a jɛ fo u ye fo u k'a faamu ani ka jɛ n'a ye.
- aw be kɔri bɔcogo numan jira sɛnɛkela bɛɛ la, ka taa a ke u jɛ na foro dɔ kɔɔ. K'aw to o la, aw be kunnafoni di u bɛɛ ma ninnu kan : kɔri bɔlen maracogo numan so kɔɔ, wali foro la. kɔri dɔgɔdɔgɔnin bɔ, n'a daminɛna ka jɛ. hakili toli musow ni denmisɛnw na kɔri bɔ tuma la. k'a jira ko : kɔri sugu don, mɔgɔ jɛ file t'a la.

Aw ka da a la ko ni kɔri bɛɛ kɛra numan ye, ka jɛ kɔsɛbɛ, a be ke sababu ye ka nɔgɔya ke Mali jamana ye a feereli la.

### 3. Sannifeere laben cogo

Sani sannifeere don ka se, tɔn nɛmɔgɔw bɛ fɛn dama dɔw sigi sen kan :

- ka basikili bila ka taa sɛgɛsɛgɛ n'a ka ni kɔɔri sɛnɛ baarada fɛ.
- ka kɔɔrita mobili siraw labɛn, ani ka kɔɔri feere yɔɔ siɛn.
- ka bɛɛ ladɔnniya kɔɔri san don na.
- sannifeere tɛ taa fɛn o fɛn kɔ, ka o bɛɛ sigi sen kan.

#### Basikili sɛgɛsɛgɛli

San o san, yanni sanni ka damine, a wajibiyalen don basikili bɛɛ ka sɛgɛsɛgɛ, k'a jira ko u bɛɛ labɛnnen don sannifeere kama a dɔnbaga jɔnjɔnw fɛ. Ni kɔɔri sɛnɛ lakɔliden ye waati min fɔ ani ka yɔɔ min jira, bɛɛ ka kan k'o labato.

Sannifeere man kan ka kɛ ni basikili sɛgɛsɛgɛbali ye. Yamaruya tɛ mɔgɔ si bolo ka basikili yɔɔ dɔ falɛn i yɛrɛ ma, wali k'a fɔ numuw ka nɛgɛ dɔ dilan k'a don a la.

#### Siraw dilanni

Fɛn min bɛ kɛ sababu ye ka kɔɔri tali nɔgɔya mobilitigiw bolo, o ye si raw labɛnni de ye samiyɛ bannen kɔ.

O la, fo an ka siraw siɛn, ka gungurun bɛɛ bɔ, ka dingɛw geren ni bɛlɛkise ni bɔgɔmugu ye. Siraw sanfɛ jiribolow bɛ tige, minnu bɛ se ka mobili basi fara ka kɔɔri bɔn dugu ma. Pɔnw fana bɛ dilan.

Ni sira kura ka kan ka bɔ, an k'an hakili to a la k'a kɛ sira tilɛnnen ye, min ka surun.

Ni sira dilan baara ka bon duguma, a ka fisa k'a fɔ joona kɔɔri sɛnɛ lakɔliden ye, o ka dabali tige a kama.

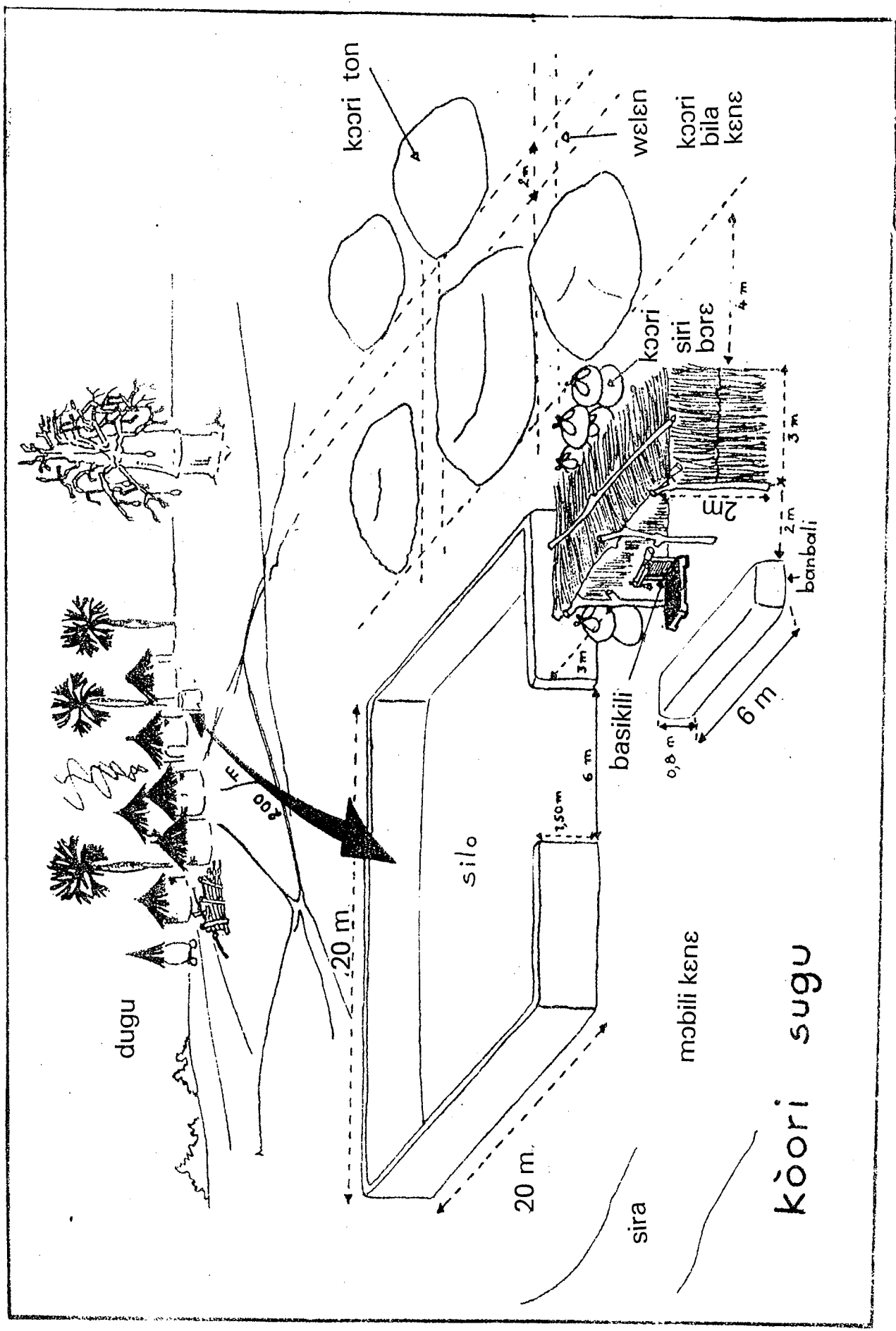

## Kɔɔri dɔɔɔ labenni

Kɔɔri dɔɔɔ bɛ labɛn, i n'a fɔ jɛgɛn b'a jira cogo min.

### Kɔɔri so (silo)

Kɔɔri sannen bila yɔɔɔ (silo) bɛ kɛ kare ye, k'a kɛrɛ bɛn mɛtɛrɛ 20 ma. A don da ye mɛtɛrɛ 6 ye, k'a kogo kundama kɛ mɛtɛrɛ kɛlɛn ni tila ye. A kɔɔɔ ka kan ka furan k'a jɛ.

A ni dugu kɔɔɔna cɛ man kan ka dɔɔɔya ni mɛtɛrɛ 200 hake ye ; silo kɔ ka kan ka sɛnɛn ka jaganaga bɛɛ furan fo mɛtɛrɛ 10 jɔɔɔn. O bɛɛ kun ye ka kɔɔri tanga kasaara bɛɛ ma, i n'a fɔ tasuma n'a jɔɔɔn wɛrɛw. Bari, kɔɔri sannen bilalɛn silo kɔɔɔ, a bɛ dugu taya la hali bi.

A lasɔɔli ka kan ka nɔɔɔya, a bɛ kɛ kɔɔritamobili sira da la.

### Sanni kɛ ga

Sannikɛlaw ka ga ka kan ka bili ka jɛ. A jɔɔan ye mɛtɛrɛ 6 ye, k'a jɔsurun kɛ mɛtɛrɛ 3 ye, k'a kundama kɛ mɛtɛrɛ 2 ye. A bɛ jɔ ka sin kɛjɛka ma, walasa tile kana don a kɔɔɔ. A bɛ jɔ ka banamini silo ma.

### Kɔɔritamobili lafa yɔɔɔ

O ye banbali ye, min jɔɔan ye mɛtɛrɛ 6 ye, k'a jɔsurun kɛ mɛtɛrɛ kɛlɛn ni tila ye, k'a kundama kɛ santimɛtɛrɛ 80 ye. O ka kan ka labɛn k'a jɛ.

### Sanni kɛnɛ

Sɛnɛkɛla b'u ka kɔɔri ton sanni kɛ ga kɔ fɛ. Taama siraninw bɛ bɔ kɔɔri ton yɔɔɔ ni jɔɔɔn cɛ, walasa wotorow ka munumunu yɔɔɔ sɔɔɔ ani ka kɔɔri sirili nɔɔɔya.

Jamanama ni binw bɛ cɛ ka bɔ sanni kɛnɛ kan.

Kɔɔri siri man kan ka dɛn kɔɔri mara yɔɔɔ kogow la, walasa kɔɔriw kana jaganami.

### Labɛnni wɛrɛw

Yanni sanni don ka se, tɔn jɛmɔɔɔw ka kan ka fɛɛrɛ siri, min b'a to u ka sanni jɛkulu mɔɔɔw bɛ se ka kalan kɛ, k'u labɛn sanni jɛ.

Sanni minɛn misɛn ka kan ka san, i n'a fɔ sɛbɛnw ni bikiw. I komin, an b'a dɔn ka kɔɔri dɔɔɔ gɔngɔn ka ca. O la, a ka fisa biki santa ka caya : hali ni biki dɔ kɛra tɛjɛfɛn ye, baara tɛ jɔ. Ni jatɛminɛ mansin tɛ yen, o fana ka kan ka san.



## 4. Sannifeere jekulu

Sannikelaw hake ye mogo 5 wali mogo 6 ye :

- peselikela ni a kankarɔsigi,
- wari sebɛn dilanna (wɛcɛlikela),
- sebɛnnikela mogo fila,
- kɔɔri filela n'a ka mogoɔw. U ka baara ye kɔɔri sugu labɛnni ye, k'a baara bɛɛ nɔgɔya.

Ni o mogo bɛɛ ma se ka sɔɔɔ dugu kɔɔɔ, k'a d'a kan mogo kalannen caman tɛ yen folɔ, sannifeere tɛ seka jɛ mogo minnu kɔ, o ye mogo saba ye :

- peselikela,
- wari sebɛn dilanna,
- kɔɔri filela.

Sannikelaw ka baaraw filɛ nin ye :

### Peselikela n'a kɔɔɔsigi

#### Yanni sanni ka daminɛ

Ni u kalanna u san folɔ la ka ban, san o san seginkanni bɛ kɛ o kalan kelen kan yanni sannifeere ka daminɛ. Ni gafe b'u bolo, min tɔgɔ ye ko "basikililabaara", u bɛ se k'o gafe kalan : peseli kɛcogo sebɛnnen bɛ o gafe kɔɔɔ, k'a pereperelatigɛ.

Yanni sanni ka daminɛ, peselikela bɛ basikili sigi yɔɔɔ labɛn, ka basikili sigi, k'a labɛn, k'a kɔɔɔɔ n'a jɛna ni kilo 2 puwa ye, ani kilo 5 puwa, walima kilo 10 puwa.

#### Peseli tuma mana se

Peselikela bɛ peseli kɛ, ka bɔ kɔɔri ton dɔ la ka ta dɔ la, ka bɔ da fɛ fo a ka ban : kɔɔri siri bɔɛɛ kelen kelen walima fila fila bɛ sigi basikili la.

Peselikela bɛ kɔɔri peselen kilo hake jɔnjɔn fɔ bamanankan na, k'a faranfasi konuman.

Min bɛ fɔ, o ye kɔɔri kilo hake ye, kɔɔri siri bɔɛɛw kilo hake bɔlen kɔ a la. Bɛn bɛ kɛ dugu kɔɔɔ kɔɔri siri bɔɛɛw kilo hake tigɛta kan sani sannifeere ka da minɛ.

O kɔ, peselikela b'a jini mogoɔw fɛ, u ka kɔɔri peselen jigin, ka dɔ wɛɛ yɛlɛn.

Ka peselikela to a ka baara la, a kɔɔɔsigi fana b'a jan to a la, k'a nɔminɛ fili ko ta fan fɛ.

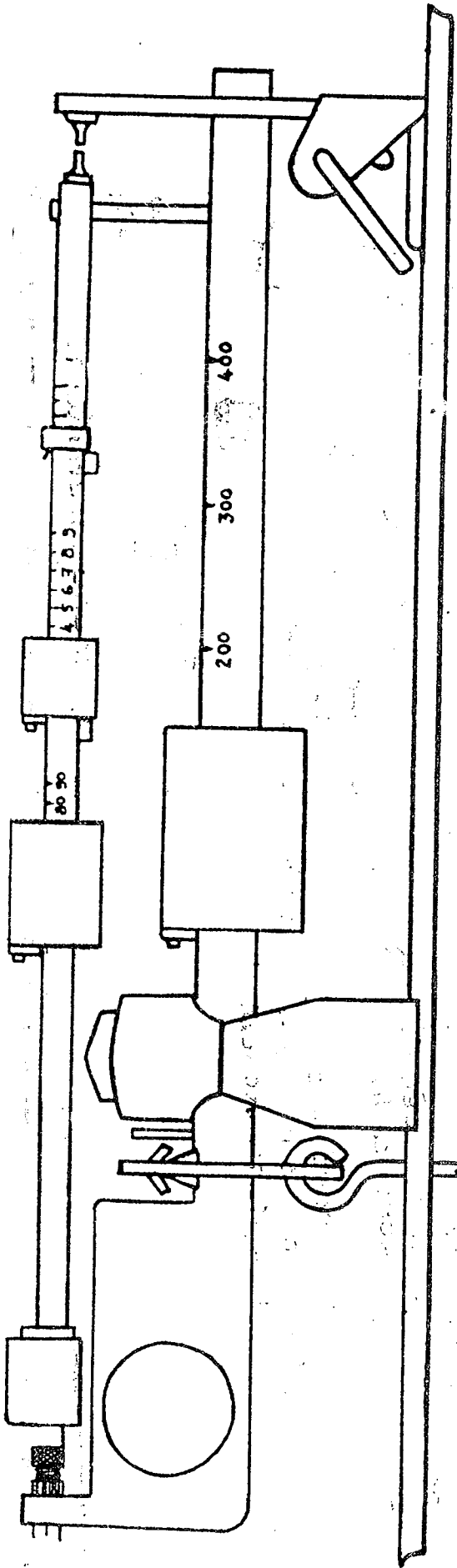

basim

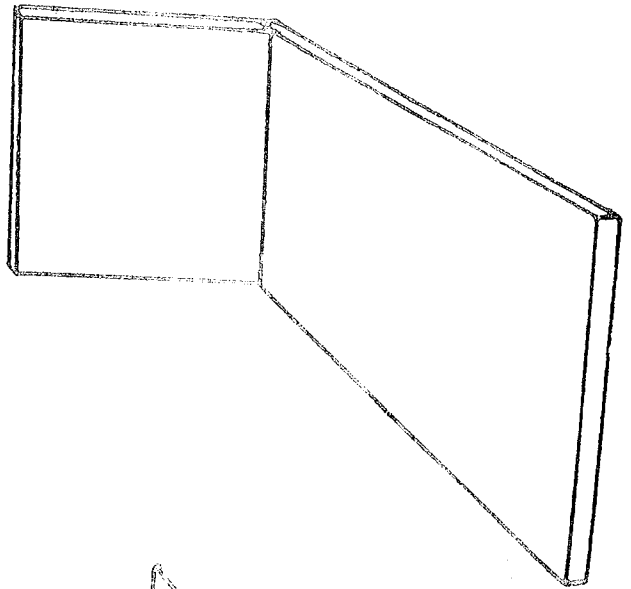
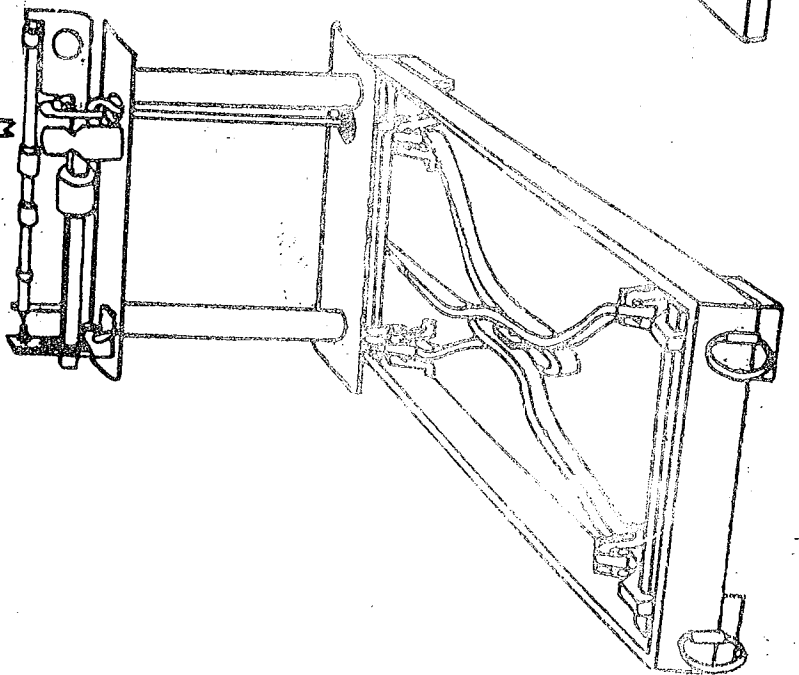

Koori lajeli

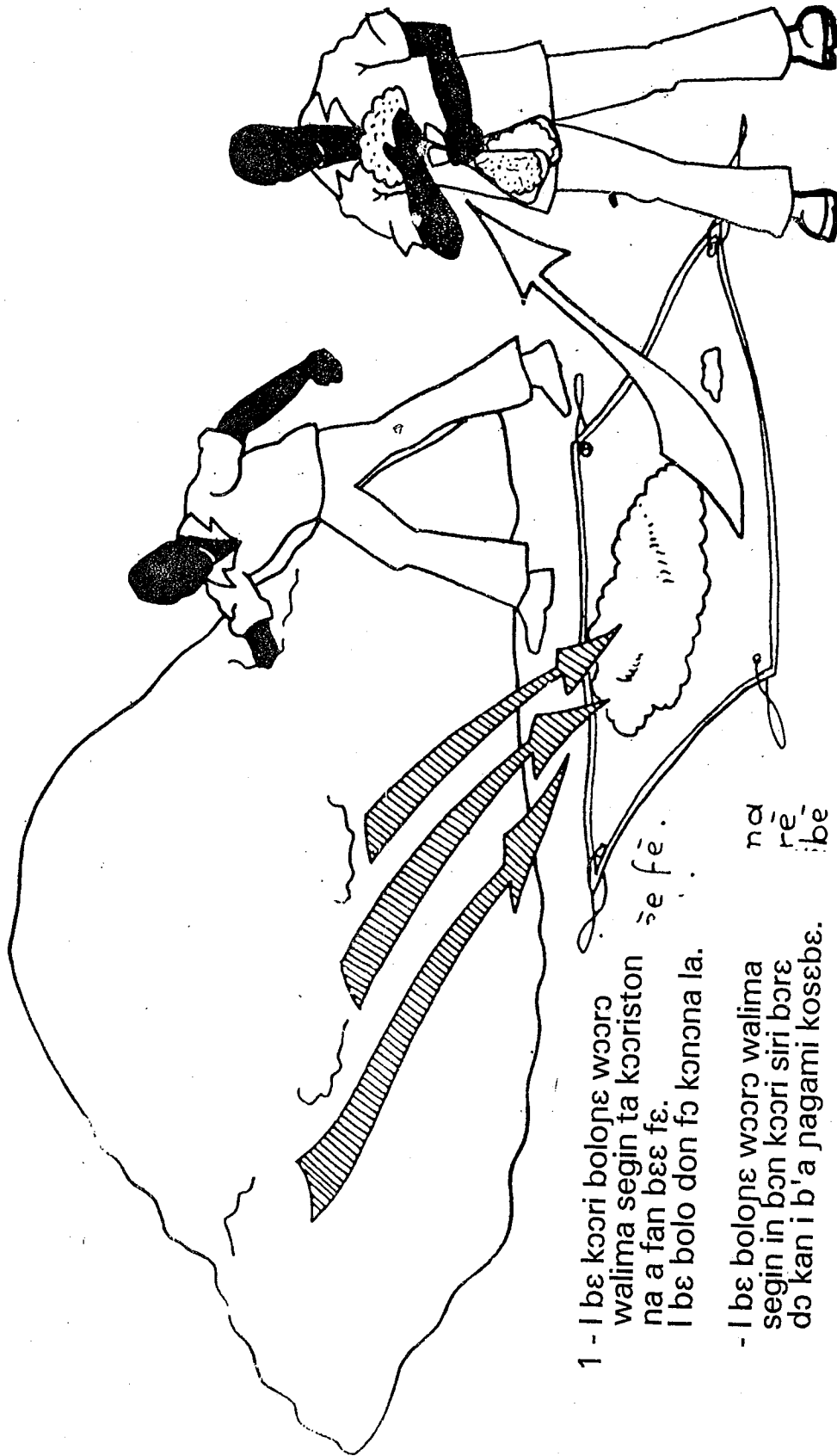

- 1 - I be koori bolone wooro walima segin ta kooriston na a fan bee fe. I be bolo don fo kooona la.
- I be bolone wooro walima segin in bon koori siri bore do kan i b'a nagami kosebe.

2 - I be soro k'o koori do ta, ni ka segesege ni koori segesege manaboreninw ta ye.

na  
re  
ibe

## Kɔɔri filela

### Yanni sanni ka damine

Ni a ka san folo kalan tɛmɛna, san o san seginkanni bɛ kɛ a ye, ka kɛ hakili jigin ye a fɛ.

A ka baara ye kɔɔri doɔgo labɛnni ye sannifeere kama. A ka kan ka sannifeere jɛbil baaraw kɛ kɔɔri doɔgo dilanta fan fɛ, i n'a fo, kɔɔriso labɛnni, sannikelaw sigi ga labɛnni, kɔɔriso da la banbali dilanni, ani sanni kɛ yɔɔɔ bɛɛ saniyali.

### Sanni tuma na

A bɛ sɛnɛkɛla ka kɔɔri bɔn yɔɔɔ jira i la, janko tɛmɛ cogo ka nɔɔɔya kɔɔri tonw ni jɔɔɔn cɛ, ani kɔɔri kana jɔɔɔmi jɔɔɔn na.

A bɛ baara kɛ ni mana bɔrɛnin fila ye, n'o ye kɔɔri jɛman ni woloma bali sangelen ye. Kɔɔri bɛ u bɛɛ kɔɔɔ : kɛlen, kɔɔri juman bɛ o kɔɔɔ ; filanan, kɔɔri wolomabali bɛ o kɔɔɔ. O kɔɔriw n'o manaw bɛ bɔ kɔɔrisɛnɛbaarada la.

A bɛ baara kɛ ni sɛbɛn kunkurunin saba ye : sɛbɛn jɛman, o ye kɔɔri juman sɛbɛn ye, sɛbɛn nɛrɛmuguman, o ye kɔɔri wolomabali sɛbɛn ye.

Kɔɔri filela b'a jira cogo di ko kɔɔri ka ni wali kɔɔri man ni ?  
a b'a bolo ka kɔɔri ton na sijnɛ 6 wali sijnɛ 10, ka olu jɔɔɔmi jɔɔɔn na kɔɔri siri bɔrɛ do kan, ka sɔɔɔ ka o ni a ka bɔrɛnin fila taw da jɔɔɔn kɔɔɔ. O waati, a n'a ka kɔɔrifilɛjamakulu bɛ sɔɔɔ ka u dantigɛ kɔɔritigi ye a yɛrɛ jɛ na. O kɛlen kɔ, a ni sɛbɛn min ka kan, a tɔɔɔ bɛ sɛbɛn o la, k'a tigɛ, k'a di a ma.

## Wari sɛbɛn dilanna (wɛɛɛlikɛla)

### Ale ka baara kɛ minɛnw filɛ nin ye :

- peselikɛ kayɛ ani wɛɛɛli kayɛ ;
- kɔɔri filela bɛ sɛbɛn min di sɛnɛkɛla ma, o sɛbɛn kɔ ye a ka baarakɛ yɔɔɔ do ye.
- kɔɔri sɔɔɔgo sɛbɛn (baremu), ani jate kɛ mansin.

### A ka baara filɛ nin ye :

- a bɛ peselikɛ kayɛ lafa : ka sɛnɛkɛla tɔɔɔ n'a jamu sɛbɛn, ani kɔɔri siri bɔrɛ hake, ani u kilo hake minnu fɔra peselikɛlaw fɛ.
- a bɛ kilo hake peselenw kafo jɔɔɔn kan peseli tuma na. Hake min bɛ sɔɔɔ a la, k'o ni sɛbɛnnikɛlaw ta da jɔɔɔn kɔɔɔ.
- a bɛ kɔɔri wari hake jate ni kɔɔri sɔɔɔgo sɛbɛn (baremu) ye, wali jate kɛ mansin.
- a bɛ kilo hake ni wari hake sɛbɛn kɔɔri filela ka sɛbɛn dilɛn kɔ kan, ka o kilo hake n'o wari hake sɛbɛnnen fo sɛnɛkɛla ye, ka sɔɔɔ ka sɛbɛn di a ma.
- ka kilo hake ni wari hake sɛbɛn wɛɛɛli kayɛ kɔɔɔ sɛnɛkɛla tɔɔɔ jɛ fɛ. O yɔɔɔ bɛɛ, a bɛ o wari wɛɛɛ cogo sɛbɛn wɛɛɛli kayɛ kɔɔɔ.

Peseli kaye  
Koori girinya jateminε seben

<p>11/12/85</p> <p>Dirisa Tarawele</p> <p>166 171 <u>337</u> 159 <u>496</u> 183 <u>679</u> 158 <u>837</u></p>			
<p>Mamadu Jalo</p> <p>165 171 <u>336</u> 168 <u>504</u> 175 <u>679</u> 157 <u>836</u> 168 <u>1004</u> 162 <u>1166</u></p>			

sɛnɛkɛla ka seere			sɛnɛkɛla ka seere		
tɔgɔ .....			tɔgɔ .....		
jamu .....			jamu .....		
kɔɔri suguya .....			kɔɔri suguya .....		
kilo hake	kilo kelen songɔ	a mumɛ songɔ	kilo hake	kilo kelen songɔ	a mumɛ songɔ
X	=		X	=	
don ..... sɛbɛnnikɛla bolonɔ			don ..... sɛbɛnnikɛla bolonɔ		
.....			.....		
sɛnɛkɛla ka seere			sɛnɛkɛla ka seere		
tɔgɔ .....			tɔgɔ .....		
jamu .....			jamu .....		
kɔɔri suguya .....			kɔɔri suguya .....		
kilo hake	kilo kelen songɔ	a mumɛ songɔ	kilo hake	kilo kelen songɔ	a mumɛ songɔ
X	=		X	=	
don ..... sɛbɛnnikɛla bolonɔ			don ..... sɛbɛnnikɛla bolonɔ		
.....			.....		
sɛnɛkɛla ka seere			sɛnɛkɛla ka seere		
tɔgɔ .....			tɔgɔ .....		
jamu .....			jamu .....		
kɔɔri suguya .....			kɔɔri suguya .....		
kilo hake	kilo kelen songɔ	a mumɛ songɔ	kilo hake	kilo kelen songɔ	a mumɛ songɔ
X	=		X	=	
don ..... sɛbɛnnikɛla bolonɔ			don ..... sɛbɛnnikɛla bolonɔ		
.....			.....		

Koori numan sansongo seben  
kilo 1 songo = dorome 17

kilo hake	songo	kilo hake	songo	kilo hake	songo	kilo hake	songo	kilo hake	songo
1	17	26	442	51	867	76	1292	100	1700
2	34	27	459	52	884	77	1309	200	3400
3	51	28	476	53	901	78	1326	300	5100
4	68	29	493	54	918	79	1343	400	6800
5	85	30	510	55	935	80	1360	500	8500
6	102	31	527	56	952	81	1377	600	10200
7	119	32	544	57	969	82	1394	700	11900
8	136	33	561	58	986	83	1411	800	13600
9	153	34	578	59	1003	84	1428	900	15300
10	170	35	595	60	1020	85	1445		
11	187	36	612	61	1037	86	1462		
12	204	37	629	62	1054	87	1479	1000	17000
13	221	38	646	63	1071	88	1496	2000	34000
14	238	39	663	64	1088	89	1513	3000	51000
15	255	40	680	65	1105	90	1530	4000	68000
16	272	41	697	66	1122	91	1547	5000	85000
17	289	42	714	67	1139	92	1564	6000	102000
18	306	43	731	68	1156	93	1581	7000	119000
19	323	44	748	69	1173	94	1598	8000	136000
20	340	45	765	70	1190	95	1615	9000	153000
21	357	46	782	71	1207	96	1632	10000	170000
22	374	47	799	72	1224	97	1649		
23	391	48	816	73	1241	98	1666		
24	408	49	833	74	1258	99	1683		
25	425	50	850	75	1275	100	1700		

## Sebennikela fila

### Sebennikelaw ka baarakeminenw file nin ye :

- peselike kaye. U ka peselike kaye ni wɛɛlikela ta bɛɛ ye kelen ye.
- senekelaw ka juruseben.
- kɔɔri songo seben, wali jatekemansin.
- pɔnbasikili sebenw.

### U ka baara file nin ye :

- u bɛ kilo hake peselenw kafo ɲogon kan peseli tuma na. I n'a fa, wɛɛlikela b'a kɛ cogo min.
- u bɛ kɔɔri wari hake jate ni kɔɔri songo seben ye, wali jatek mansin, wɛɛlikela b'a kɛ cogo min.
- u bɛ kɔɔri kilo hake n'a wari hake seben senekela ka juruseben kɔɔ.
- ni mobili do nana kɔɔri tali kama, u bɛ sɔɔ ka pɔnbasikili sebenw lafali damine :

#### 1. Kɔɔri taali kaye

u bɛ don seben, ka mobili bolibaga tɔgo n'a jamu seben ka mobili n'a wotoro nimɔɔw bɛɛ seben, ani pɔnbasikili seben nimɔɔ, ani kɔɔri talen kilo hake.

#### 2. Pɔnbasikili seben

O sebenw bɛ di pɔnbasikilitigi de fa. O seben kelen kan, i bɛ senekela tɔgo sebennen ye (n'o tigi kelen ye mobili fa), wali dugu tɔgo, ani kɔɔri talen kunnafoniw bɛɛ.





## Panbasikili seben

nin ye panbasikili  
seben nimoro ye.

TESUT - EQUITA	Sekiteri : Maraka kungo	N° 1204
	Zeri : Zangena	
	S.B. : Balan	13 710 kg ①
	A.V. : Yola	9 350 kg ②
dugu	4 0185	6 360 N ③
C 1761		
Choix 1e 3 x B.1.c3		

peseli  
don

koozi suguya      kamyon  
nimoro

- . kunnafoni ① kamyon falen girinya di
- . kunnafoni ② be kamyon lankolon girinya di
- . kunnafoni ③ be koozi talen girinya di : n'i ye

Kamyon lankolon girinyaa bo a falen ta la, o be ben koozi talen girinya ma.

## 5. Kɔɔri taali izini la

### Kɔɔri taali

Ni mobili be yen, kɔɔri peselen be don a kɔɔɔ o yɔɔɔnin beɛ. Ni mobili te sanni keɛ kan, kɔɔri be mara silo kɔɔɔ fo mobili do ka na.

Ni kɔɔri senɛnaba be dugu min na, n'a ka kɔɔri be se ka mobili fa, wali ka mobili wotoronin fa, o tigi ka kɔɔri te pese dugu basikili la, o be ta ka taa pese izini oɛnbasikili la. Kilo hake min mana sɔɔɔ o kɔɔri la, o be jate ka fara dugu ka kilo hake kan.

Mɔɔɔ min ka kɔɔri mana ta o cogo la, o tigi be bolomafara don tɔn ka keɛsu la.

Mobili si man kan ka taa ni kɔɔri ye, k'a sɔɔɔ dugu mɔɔɔ ma da a kan. Mobili te pese pɔnbasikili la o tigi ko, pɔnbasikili seɛn be di a ma.

### Kunnaɔoniw pɔnbasikili ni dugu ce

Dugu be kunnaɔoni di pɔnbasikili ma a ka cidenw fe.

- kɔɔri hake sannen,
- k'a jira n'u mago be mobili la o dugu je,
- k'a jira ko kɔɔri to be silo kɔɔɔ, wali k'a jira ko kɔɔri banna.

Pɔnbasikili fana be kunnaɔoni di dugu ma a ka cidenw fe, wali mobili bolibaga ka seɛn fe :

- mobili fa n'a fabaliya
- mobili sɔɔɔli n'a sɔɔɔbaliya,
- ani kunnaɔoni fen o fen ka kan ka lase dugu ma.

## 6. Kɔɔri wari sarali

### Wɛɛɛli kɛ cogo

Fɛn min ye wɛɛɛli baara ye, a bɛ kɛ sɛnɛkɛla bɛɛ kelen kelen de tɔɔɔ la wɛɛɛlikɛlaw fɛ. Sɛbɛnnikɛlaw fana b'o baara kelen kɛ u ka sɛbɛnw kɔɔɔ.

O baara kɛcogo file nin ye : sɛnɛkɛla kelen kelen ka kan ka wari min sɔɔɔ, o bɛ wɛɛɛ :

- dɔɔɔmɛ 2000 biye hake min bɛ di a ma,
- dɔɔɔmɛ 1000 biye hake min bɛ di a ma,
- dɔɔɔmɛ 200 biye hake min bɛ di a ma,
- dɔɔɔmɛ 100 biye hake min bɛ di a ma,
- dɔɔɔmɛ 20 ganan hake min bɛ di a ma,
- dɔɔɔmɛ 10 ganan hake min bɛ di a ma,
- dɔɔɔmɛ 5 ganan hake min bɛ di a ma,
- dɔɔɔmɛ 2 ganan hake min bɛ di a ma,
- dɔɔɔmɛ 1 ganan hake min bɛ di a ma.

Wɛɛɛli kaye kɔɔɔ, sɛnɛkɛla bɛɛ tɔɔɔ jɛ fɛ, i bɛ kɔɔri girinya, a wari hake n'a wɛɛɛ kɛ cogo sɛbɛnnen ye.

N'o baara banna wɛɛɛli kaye kɔɔɔ, wɛɛɛlikɛla bɛ sɔɔɔ k'a kɔɔɔɛ, ka sɔɔɔ ka wari suguya kelen kelen hake jate, k'u da jɔɔɔɔn kɔɔɔ. O b'a to, a k'a dɔɔn, a mago bɛ wari suguya kelen o kelen hake min na ka dugu mumɛ ka kɔɔri wari sara.

O bɛɛ lajɛlen bɛ bɛn wari hake min ma, o fana bɛ jate. Min mana sɔɔɔ a la, o ka kan ka bɛn ni dugu mumɛ ka kɔɔri taalen sɔɔɔ ye. N'o fila ma kɛ ke len ye, o kɔɔɔ ye ko fili kɛra, wɛɛɛlikɛla ka kan ka o fili yɔɔɔ jini. San wari ka ta, a ka jɛ wɛɛɛlikɛla ka wɛɛɛli kaye jira lakɔɔliden na, wali balikukalan kunti gi la, olu k'a sɛmentiya ko fili t'a la.

### Kɔɔri wari dili dugu ma kɔɔrisɛnɛbaarada fɛ

Tɔɔn duguw ka wari sarali bɛ kɛ kɔɔri sɛnɛ baarada ka kɔɔri san jamakulu fɛ, wali cikɛ kuntigi fɛ.

Wari suguya saba de bɛ di dugu ma :

1. wari min bɛ tila sɛnɛkɛlaw ni jɔɔɔɔn ɛɛ, n'o bɛ bɛn u ka kɔɔri feerelen wari ma. O wari ka kan ka bɛn wɛɛɛlikɛla ka wari wɛɛɛɛlen ma a ka kaye kɔɔɔ.  
minnu ta pesera dugu kɔɔɔ wo, minnu ta pesera pɔnbasikili la wo, o bɛɛ ta b'a la.
2. min yɛlɛnna kɔɔri kan, o wari fana bɛ sara. O ye wari ye min bɛ sɔɔɔ pɔnbasikili peseli ni dugu peseli ni jɔɔɔɔn ɛɛ.
3. dɔɔɔ la baara sara : wari min bɛ sɔɔɔ dɔɔɔ la baara sara ye, o wari jate bɛ minɛ dugu ka kɔɔri feerelen na : o tɔni kelen da jate minenen don san o san kɔɔri sɛnɛ baarada fɛ.

O wari suguya saba jatɛlen don kɔɔri sɛnɛ baarada wari sarala fɛ, k'a di tɔɔn dugu ka wari talaw ma. Sɛbɛn fana bɛ di u ma, kunnafoniw bɛɛ bɛ sɔɔɔ min na, ka kɛ seereya ye.



## **Sɛnɛkɛlaw ka kɔɔri wari sarali**

O baara bɛ kɛ wɛɛɛlikɛlaw ni sɛbɛnnikɛlaw fɛ.

Sɛnɛkɛlaw tɔɔɔ bɛ wele kelen kelen, i n'a fɔ, a bɛ wɛɛɛli kaye kɔɔɔ cogo min na.

Bɛɛ k'i ka kɔɔri wari sɛbɛn jira, ka sɔɔɔ k'i ka wari minɛ.

Tɛmɛ tɛ kɛ mɔɔɔ si kan, a bɛ ta da fɛ, fo k'a foori.

Ni min ka wari dira a ma, o tigi b'a tilen juru kanilaw ma, k'a ka juru bɛɛ sara yanni a ka taa so.

## **a' y'a to a' hakili la**

### **Kɔɔri kɔɔɔsili**

Kɔɔri kɔɔɔsili ye sannifeere baara dɔ de ye.

O la, kɔɔri kɔɔɔsili wajibiyalen don dugu yiriwa tɔn bɛɛ ma, k'a d'a kan, kɔɔri b'u yamaruya kɔɔɔ, fo a tuma kɔɔri sɛnɛ baarada fɛ.

### **Mobili lafa cogo**

Ni mobili taara aw ka kɔɔri ta, a' y'a jija k'a don kɔsɛbɛ, k'a teliya la, ani k'a siri ka jɛ.



# san wari jate bò siraw

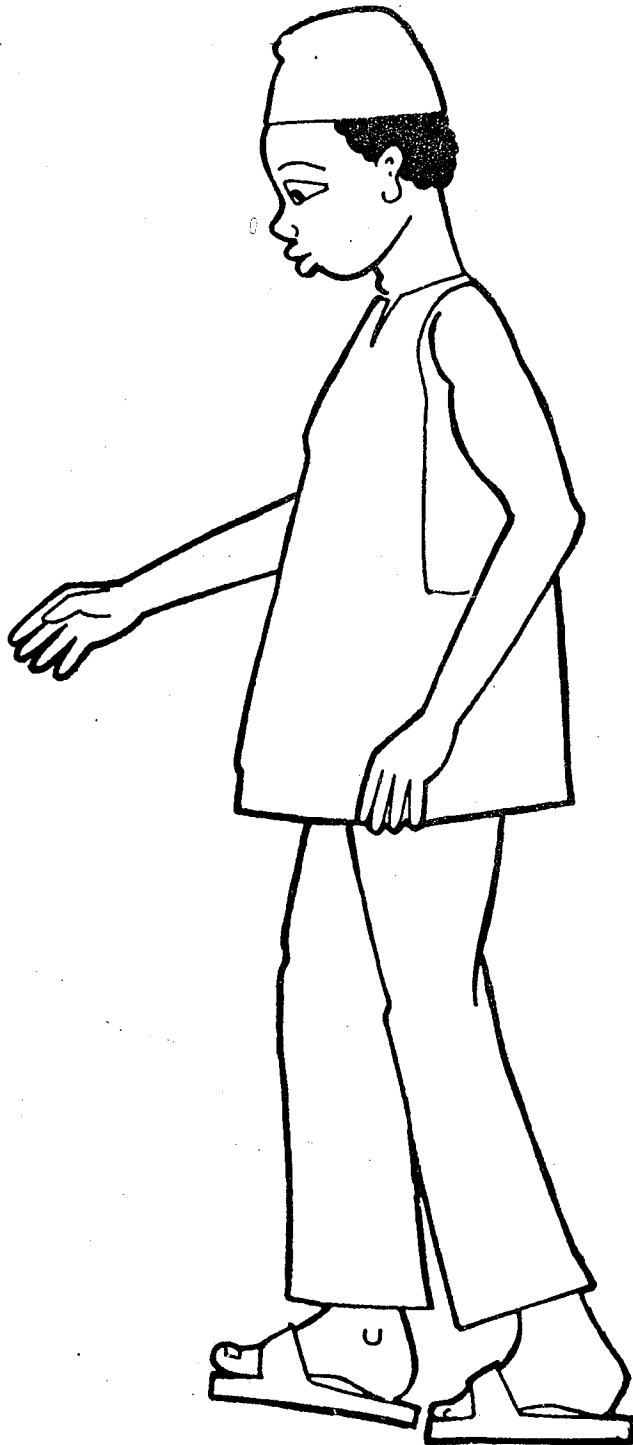



## 1. Kesu jefoli seben

Mago mago te je wari ko. Du mago te je wari ko. Duguyiriwa ton fana be ten. O de y'a to, kesu be ton bolo, ni wari be bila min kono. O de y'a to fana, wari marala be sigi ka kesu in kolosi, ka ton ka wari mara kopuman, a kana tunun, a ka tije.

Bee haminanko ye ton ka wari ko ka ke ko jelen ye, nanbara kana don a la. O la, kaye do be di wari marala ma, n'a togo ye ko "kesu jefoli seben".

- wari o wari be don ton ka kesu kono (i n'a fo dogolabaara sara sanni feere tuma, tonforo ka tona, wari talen banki la...), o bee be seben o kaye kono, k'a pereperelatige).
- wari o wari be bo kesu kono (i n'a fo, wari min be ke ka magone fen san, juru min be don mago la, wari min be taa bila banki la...), o fana bee be seben o kaye kelen kono, k'a pereperelatige.

N'a kera o cogo la, nanbara te don wari ko la. Bawo, wari donnen kesu kono wo, wari bolen kesu kono wo, a dun kun n'a bo kun, o bee sebennen be, ani kesu kono wari ka kan ka ben hake min ma.

N'an ye kaye in laje, k'a tanuman fe, ka na kinin fe, so duuru b'a kono :

### Kesu jefoli seben ka so duuru

#### 1. don

a kera wari donni ye wo, a kera wari boli ye wo, o ke don ka kan ka seben don so kono. O seben cogo ye : san / kalo / tile. I n'a fo : 85 / 11 / 21, n'o koro ye : san 1985, kalo tan ni kelennan, tile 21.

#### 2. danfara

ni wari min worola, wali ni wari min musakara, o kun ka kan ka pereperelatige danfara so kono. Ni seben dara wari kan (i n'a fo seere seben), o seben nimoro be se ka seben danfara so in kono.

#### 3. dontaw

wari min be don kesu kono, o da be seben dontaw so kono.

#### 4. botaw

ni wari min bora kesu kono, o da be seben botaw so kono.

#### 5. kesu kono ta

waati o waati, n'i ye fen seben dontaw so kono, walima botaw so kono, i be kesu kono ta so lafa : ni wari min donna, o hake be fara sebennen koro kan. Ni wari min bora, o hake be bo a la. hake min sebennen be kesu kono ta so la, o ni kesu kono wari hake ka kan ka ke kelen ye. N'o ma ke, an b'a don o la ko fili kera.

### Laadilikan

- jatedenw ka kan ka sigi kopuman jogon koro. O be jatemine nogyawa aw bolo.
- nimoro be sigi kesu jefoli seben je kelen kelen bee la. O kaye in je si man kan ka fara abada.
- kesu jefoli seben ka kan ka saniya. Hali n'i filila yoro min na, i be tiiri cii o kan, k'a seben kura ye. O kaye be lasagon yoro puman na.

## Kesu pefoli seben san 1981 - 1982

Don	Danfara	Dontaw	Botaw	Kesu kono ta
11/1/81	Salon wari to			30085
11/21	kooi dogolabaara sara (fola) kg 112430 x t 2,8 =	62961		93046
11/21	kooi sannifeere kunnata kg 620 x d 26	16120		109166
11/21	sannike jekulu ka saga songo		1500	107666
"	" " " malo songo		7000	100666
"	" " " na songo		2000	98666
"	sannike jekulu ka minen misenw		1500	
11/25	kooi bilasiralaw ka dumuni songo		2400	97166 94766
11/25	mapo dogolabaara sara kg 32820 x t 1,2	7877		102643
"	mapo kunnata kg 115 x d 19	2185		104828
12/15	mangasa toli songo 35 x d 900		31500	73328
"	mangasa jiri songo (m 40 x d 240)		9600	63728
"	mangasa ponti songo (kg 3 x d 400)		1200	62528
"	mangasa negejuru songo		1000	61528
"	mangasa jo sara		5000	56528
12/20	mangasa toli genge sara		6000	50528
1/15/82	niwakini san songo		9000	41528
1/16	kooi dogolabaara sara (filanan) kg 54840 x t 2,8	30711		72239
"	kooi kunnata (filanan) kg 386 x d 26	10036		82275
1/20	petoroli songo (l 64 x d 71)		4544	77731
2/1	seben mara kesu		1000	76731
2/2	gafe songo (50 x d 160)		8000	68731
3/2	sanni jekulu nisondiyalan		10000	58731
"	tinminemusow		3000	55731
"	dogotorow nisondiyalan		4000	51731
3/12	madu ka juru sara	1250		52981
3/13	wari bilalen banki la		20000	32981
3/15	dirisa ka juru sara	3000		35981
3/17	birama ka juru sara	800		36781
3/20	zofere ka pangini sara		20000	16781
3/25	dunan fana		200	16581
4/2	dugu saraka saga ni ba songo		2600	13981
4/11	shaka ka dono		2000	11981
4/15	dunan fana		1250	10731

## 2. Ninan tɔnɔ jatemiɛ cogo

Setanburu kalo ni ɔkutɔburukalo la, sani sannifeere kura ka daminiɛ, o min be wari lase tɔn ma, tɔnsigi be ke : san temenen ka wari donna da minnu fe, o be nɛfo dugu mɔgo beɛ ye.

Min be nɛfo fofo, o ye ninan san kɔnɔ tɔnɔ ye. O baara in be nɛfo nin cogo in na : an b'a jatemiɛ ko an ka forobatɔn y'a sinsin jago de kan ka wari sɔrɔ. O jago sira ye a ka baara diliman saba ye : minen kɔnɛ, juru kɔnɛ, ani sannifeere.

- wari be sɔrɔ o baara diliman saba la. O ye ninan san kɔnɔ sɔrɔw ye.
- o jago te se ka ke ni musaka ma ke. O la, musaka ninnu be wele ko :

### **tɔnɔ nɛsigi musakaw.**

O la, san sɔrɔw ni san musakaw be bo nɔgɔn na, yaasa ka ninan san kɔnɔ tɔnɔ hake don.

Kesu nɛfoli seben de b'a to ni dugu yiriwa tɔn sɔrɔw n'a musakaw be se ka don k'a dantige : wari min sɔrɔla ni musaka minnu kera baara diliman saba ko la, o beɛ be nɛnatɔmɔ kesu nɛfoli seben kɔnɔ, k'u jatemiɛ, ka ninan tɔnɔ seben laben : min ni min ka surun, olu be seben yɔrɔ kelen na. O yɔrɔ dam- adɔw file nin ye :

### **Sɔrɔw**

1. kɔri dɔgɔlabaara saraw.
2. kɔri sannifeere kunnataw.
3. nɔ dɔgɔlabaara saraw.
4. nɔ sannifeere kunnataw.
5. maɔnɔ dɔgɔlabaara saraw.
6. maɔnɔ sannifeere kunnataw.
7. mobiliba tabaga niyɔrɔ (o ye wari dilen ye kɔritigiw fe, minnu ka kɔri ma pese dɔgo la sannijekulu fe, n'u ye mobili fa ka taa n'a ye pɔnbasikili la).
8. kɔri jugu sɔngɔ (ni dugu benn'a kan ka kɔri jugu beɛ feere k'a wari bila dugu yiriwa tɔn kesu kɔnɔ).
9. dugu yiriwa tɔn sara BNDA ka juru ko kan.
10. wari jate bo kunnafa (ni fili kera : magɔnɛ minenw sarala ka wari to min to, o be bila kesu kɔnɔ... walima ni dugu juru sarala ka wari to min to, o be don kesu kɔnɔ... o n'a nɔgɔnnaw...).

### **Tɔnɔ nɛsigi musakaw**

1. minen misen sɔngɔ (kaye, biki, ɛregiliw, gɔmuw, sakɔsi, jatemiɛ man san piliw, minen misen minnu sanna sannifeere kama...), nka, minen minnu be san caman si (i n'a fo basikili, kɔri siri bɔrɛw..), olu te don ninan tɔnɔ jate la.
2. tɔndenw nisɔndiyalan, i n'a fo sannikelaw, kɔri ladonnaw, mobili bila-sirabagaw, sannifeere ni juru kalan musakaw, ani musaka fen o fen n'a be ke tɔndenw ye baara diliman saba in kan.
3. minen dilan siraw.
4. minen singa sara (basikili, kɔri siri bɔrɛ...).
5. minen tipɛlenw sara wari kɔri sene baarada ma (nɔgo walima furaji mana tipe, wali ka sɔnɛ).
6. wari jate bo deselen (ni fili kera minenw sarali wari la ka desɛ, o be bo kesu kɔnɔ...walima ni dugu juru wari da desera ni hake min ye, o bebo ke kɔnɔ... o n'a nɔgɔnnaw...).

# Ninan san tɔncɔ

Ninan sɔrow		Tɔncɔ nɛsigi musakaw	
danfaraw	dɔrcɔme	danfaraw	dɔrcɔme
kɔɔri dɔɔɔlabaara saraw kɔɔri sannifeere kunnataw nɔ dɔɔɔlabaara saraw nɔ sannifeere kunnataw maanɔ dɔɔɔlabaara saraw maanɔ sannifeere kunnataw mobili tabaga niyɔɔɔ kɔɔri jugu sɔngɔ tɔn sara BNDA ka juru ko kan wari jate bɔ kunnata		minen misen sɔngɔ tondenw nisondiyan minen dilan saraw minen singa sara minen tijelenw sara wari jatebɔ deselen   mume ninan tɔncɔ	
mume.....		mume.....	

### 3. Warije yelma cogo pinan

Tonsigi kelen in sen fe, tila mana ke pinan tona pefoli la, warije yelma cogo kera min ye pinan san kono, o fana be dantige, k'a pefo dugu mogow ye.

O be damine ni wari sorolen pefoli ye : wari min donna kesu kono ka fara pinan tona kan, o ni pinan tona yere, o be lajelen be jatemine. O wari be lajelen de be **wele ko "bolo koro warije"**.

Bolo koro warije in jatemine man go, bawo wari sorolen be sabennen be kesu pefoli seben kono.

Baara kera ni wari min ye pinan san kono, o fana be pefo, k'a jatemine, k'a wele ko **"bolo koro warije dondaw"**. Wari in donna da minnu fe, o be se ka ke musaka ye, ani juru donnen, ani wari maralen.

O be se ka jatemine, bawo o wari bolen be sabennen be kesu pefoli seben kono.

Baara ke ni wari min ye (n'o sabennen be bolo koro warije dondaw yorow la), o wari hake ni kesu kono wari hake mana kafa pogon kan, o mume hake ni bolo koro warije hake ka kan ka ke kelen ye. N'o ma ke, fili kera yoro do la.

Bolo koro warije ni bolo koro warije dondaw be seben tuma min, min ni min ka surun, olu be seben yoro kelen na. O yorow file nin ye :

#### Bolo koro warije

1. salon wari to.
2. salon minen to feerelenw (nogo wali posoni minnu ye san yelma manga sa kono).
3. pinan tona : o ye wari ye, min sorola baara diliman saba jate bo la, n'o jatemine a dan ma.
4. dono sara.
5. ton ka juru talen banki la wali tondenw fe (banki walima tondenw mana juru don ton na).
6. wari talen banki la : ni wari maralen be ton bolo banki la, wali kotopere kesuba kono, n'aw ye do ta o la, o ye bolo koro warije ye.
7. bagan marabali tigiw pangili (ton be wari min bin tondenw kan, n'u ka baganw ma lamara).
8. bolomafaraw (tondenw, denmisenw ka ton, musow ka ton, ton foro ani kalan foro, o n'a pogonnaw...).
9. ton yiriwa sira tow ka wari donnen kesu kono, i n'a fo po gosi mansin, po si mansin, fura kesu, butiki, jiginew, u n'a pogonnaw...
10. ton ka minen singalen (basikili, kori siri bore, u n'a pogonnaw...).
11. deme kelenw sara, i n'a fo sanni ke jekulu mana sanni ke dugu were ye,

## Warije yelema cogo pinan

Bolo koro warije		Bolo koro warije dondaw	
danfaraw	dorome	danfaraw	dorome
salon wari to salon minen to feerelen pinan tona dono sara ton ka juru talen wari talen banki la bagan tigiw pangili bolomafaraw ton yiriwa sira tow ton ka minen singalen deme kelenw sara		<b>MUSAKAW</b> - soro yiriwa musakaw - donniya yiriwali musakaw - hadamadenya musakaw - juru saralenw - nafa sira werew  <b>JURU DONNENW</b> - donow - juru jebila - juru donnen mogo were la  <b>WARI MARALEN</b> - minen to san wari - wari bilalen yoro la  mume + kesu kono ta	
mume.....		mume.....	

**Bolo kɔrɔ warije dondaw****- Musakaw****1. sɔrɔ yiriwa musakaw :**

o ye musakaw ye, minnu nɔ be mɛɛn dugu kɔnɔ. U b'a to fana dugu b'a ka baara dilimanw ke : musakaw don, min be ke sababu ye ka nafa ladon dugu kɔnɔ.

I n'a fɔ pɔn ni sira dilanni, bagan minni yɔrɔ dilanni, misi sɔgɔ yɔrɔ jɔli, a n'a ɲɔgɔnnaw.

minen minnu be san caman si, olu sanda be bila sɔrɔ yiriwa musakaw la. I n'a fɔ tabali ni siyezi minnu sannen sannifeere kama, jate mine mansin, basikili, kɔɔri siri, bɔrɛw, puwa.

**2. dɔnniya yiriwali musakaw :**

O ye musakaw ye, minnu ɲɛsinnen be dɔnniya sɔrɔli ma.

I n'a fɔ : balikukalanso, walanba, kayew, lakɛɛ, gafew, lanpanw, gafe kɛsu, tabali, sigilanw, mobili sara (min be di dugu baara kalan denw ma n'u be taa kalan yɔrɔ la).

Kalandenw ka sirafana, karamɔgɔ nisɔndiyalan, kalanforo musakaw, o n'a ɲɔgɔnnaw.

**3. Hadamadenya sinsili musakaw :**

- sarakaw,

- dugu san yeɛma ɲɛnajɛw,

- tiyatiri labɛn, ntolatanw n'o ɲɔgɔnnaw,

- jiginniso jɔli,

- furakɛsu, niwakini sɔngɔ,

- nisɔndiyalan ka ɲɛsin niwakini dila ma, ani dugu dɔgɔtɔrɔ, tin minɛmuso, misi dɔgɔtɔrɔ, o n'a ɲɔgɔnnaw,

- kolɔnda labɛnni,

- tɔn ka demɛ ka ɲɛsin ɲɔ si mansin musaka dɔw ma (ɲɛbila sarali, demɛ ka ɲɛsin musow ka ɲɔsi ma...)

- bolomafara faama kunkow la : kiri tige musaka walima alimandiw ka ɲɛsin dugu ma, zofɛɛ ka ɲangili, kumandanso ka bolomafara ɲininen, polisi wali zandarama ka ɲangili, u n'a ɲɔgɔnnaw.

**4. Juru saralenw (kɔɔrisɛnɛbaarada ma, banki ma, tɔndenw ma...)****5. Wari min bɔra ka ɲɛsin nafa sira wɛrɛw ma : kɔɔri tulu, kɔgɔ, pɛtɔrɔli, jiginɛw, ɲɔ si mansin, ɲɔ gosi mansin, butiki, u n'a ɲɔgɔnnaw.****- Juru donnenw tɔn fɛ**

1. dɔnɔw (juru donnen tɔndenw na).

2. juru sarataw ɲɛbila (tɔn ka juru ɲɛbila ka ɲɛsin kɔɔri sɛnɛ baara ma, walima banki ma).

3. juru donnen mɔgɔ wɛrɛ la (jagokɛla n'a ɲɔgɔnnaw).

**- Maralen : wari min bɔra kɛsu kɔnɔ ka taa lamara yɔrɔ wɛrɛ.**

1. minɛn tɔ san wari (salon minɛn tɔ min sira mangasa kɔnɔ).

2. wari bilalen banki la, walima kɔri sɛnɛ baarada kɛsuba la.

## 4. San nata baaraw

N'an tilara san wari jate bo siraw nefoli la, o yoro la, an be se k'an hakili jakabo san nata baaraw la.

### San nata wari

An be se ka jatemine ke san nata sorow kan (dogolabaara saraw, kunnataw, tonforo, a n'a jogonnaw), k'a d'a kan, an be kene seneta hake don.

wa- N'an y'an sinsin san temenen musakaw kan, an b'a don, minnu  
kaw, jibiyalen don an kan : kalan musakaw, keneya sabatili musa-

sannifeere musakaw, ton ka juru sarataw, ani musaka tow minnu be ke san o san.

### San nata baara ketaw

N'o kera, an b'a don, an be se k'an kogo da baara minnu na ni wari to ye, k'a da duguden ka naniya siri kan.

Nin baara in sen fe, lakoliden ni balikukaalan kuntigi be se k'an demε ketaw jatemine na.



## 5. Jatemine mansin

Jatemine mansin be mago deme jatemine na, fo k'a ne, n'i sera a kecogo la, a baara ka teli, a fili ka dogo.  
A taamashyen n'a baara kecogo file nin ye kafoli, dɔbɔli, sigiyɔromali ani tilali kan.

### Jatemine mansin taamasinyenw :

- taamasinyen minnu b'a ne kan, olu folo folo ye **jatedenw** ye :

7	8	9
4	5	6
1	2	3
0		

### - Jatemansin baara kecogo :

ON/C o be mansin mene, ani ka jate tije ka bo yen.  
OFF o be mansin faga.  
CE o be filiw tije ka bo yen, sani ka da were seben.

### - Jatekalan taamasiyenw :

V nin ye jate do taamasiyen ye, min be nefo kalan were la.

X tilali taamasinyen  
sigiyɔromali taamasinyen.

- dɔbɔli taamasiyen.

+ kafoli taamasiyen.

= jaabi dilan.

M + ka kafoli jaabiw lasago, n'i be kafoli caman ke.

M - ka dɔbɔli jaabiw lasago, n'i be dɔbɔli caman ke.

RM ka kafoli walima dɔbɔli jaabi lasagolenw jira.

CM ka jaabi lasagolenw tije ka bo yen.

% jaabi sɔrta keme o keme kan.

ka tomi bila daw ni jɔgon ce da dafabaliw la. A be ke nkɔri ye bolo la. (Nin taamashyen be nefo kalan werew la).

### Laadilikanw

- kana pine ka mansin faga (ka OFF digi), n'i tilala jatemine na.
- i ka pili falen ni daw te bo kosebe.
- i ka mansin mara a foroko kɔno ni baara banna.

## Jateminε mansin

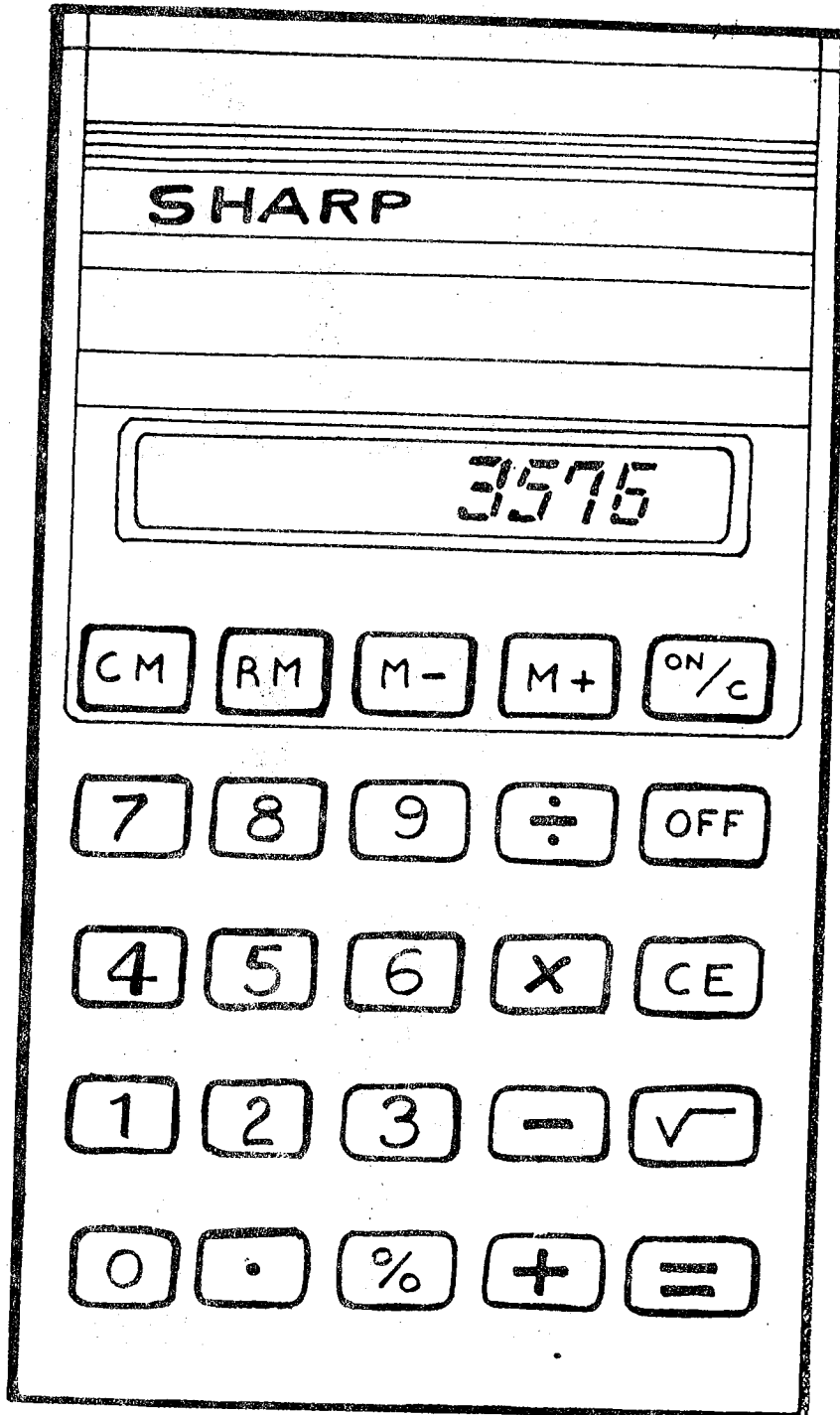

5 6 7 8 9

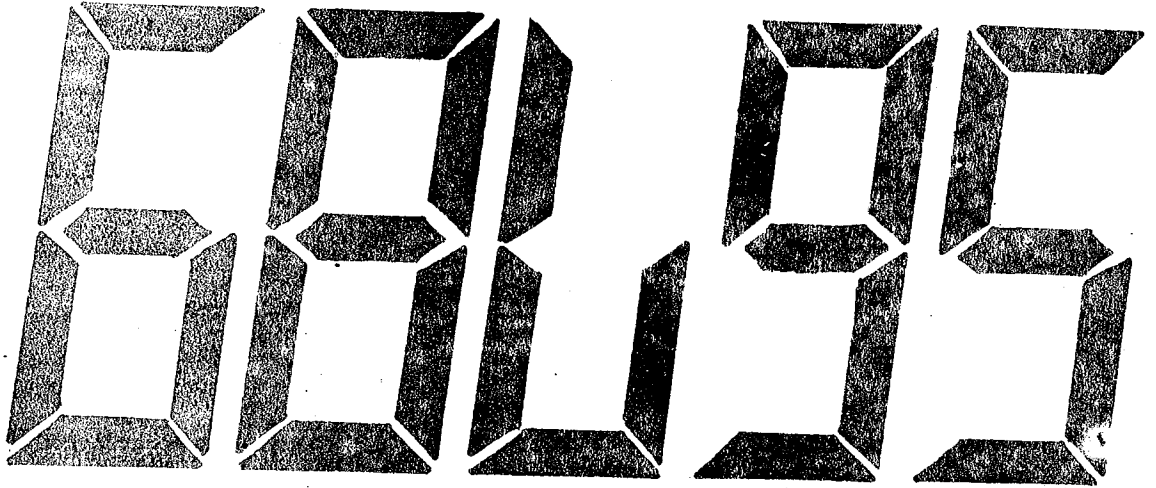

0 1 2 3 4

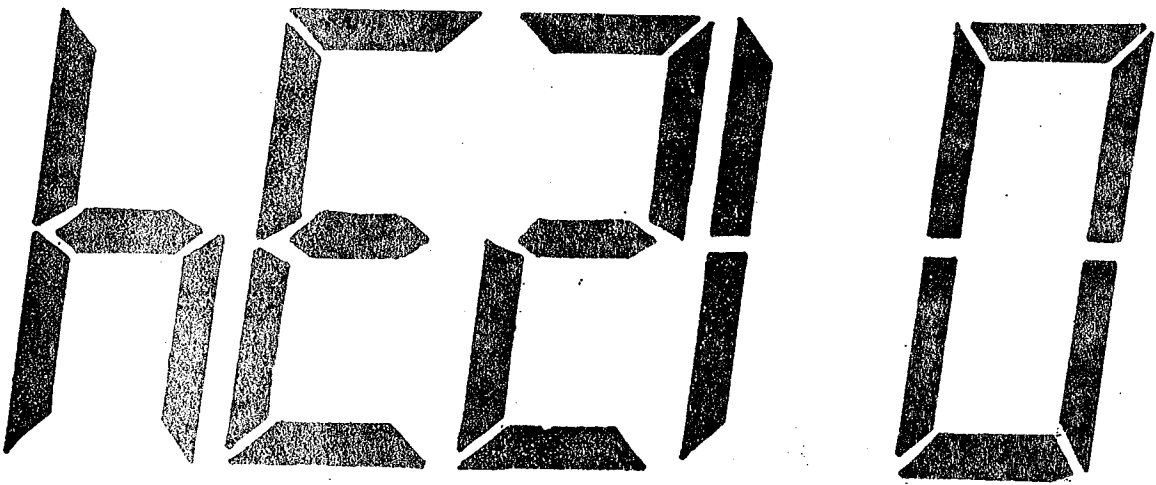

**Daw sebencogo mansin kɔɔ**

misali 5236

N'i bɛ da min sɛbɛn mansin kɔɔ, i b'a jatedenw digi kelen kelen, i n'a fo i b'a kalan cogo min na.

i bɛ foɔ ka 5 digi,

ka sɔɔ ka 2 digi,

ka sɔɔ ka 3 digi,

ka sɔɔ ka 6 digi.

O la, 5236 bɛ bɔ mansin kan.

**Kafoli kɛcogo**

misali : 5236 + 4978

I bɛ mansin mɛnɛ, ka taamasinyɛn kelen kelen digi, a sɛbɛnnen bɛ cogo min :

$$5 \ 2 \ 3 \ 6 \ + \ 4 \ 9 \ 7 \ 8 \ =$$

a jaabi bɛ bɔ : 10214.

O cogo file :

i bɛ da foɔ sɛbɛn 5236

i bɛ kafoli taamasinyɛn digi +

i bɛ filanan sɛbɛn 4978

i bɛ jaabi dilan digi sɛnɛ kelen =

jaabi bɛ bɔ i kɔɔ 10214

**Dɔbɔli kɛcogo**

misali : 9412 - 5786 =

i bɛ mansin mɛnɛ, ka taamasinyɛn kelen kelen digi, a sɛbɛnnen bɛ cogo min :

$$9 \ 4 \ 1 \ 2 \ - \ 5 \ 7 \ 8 \ 6 \ =$$

a jaabi bɛ bɔ : 3626

O cogo file :

i bɛ da foɔ sɛbɛn : 9412

i bɛ dɔbɔli taamasinyɛn digi -

i bɛ da filanan sɛbɛn 5786

i bɛ jaabi dilan digi sɛnɛ kelen =

jaabi bɛ bɔ i kɔɔ 3626

**Sigiyɔɔmali kɛcogo**

misali : 563 x 15 =

i bɛ mansin mɛnɛ, ka taamasinyɛn kelen kelen digi, a sɛbɛnnen bɛ cogo min :

$$5 \ 6 \ 3 \ \times \ 1 \ 5 \ =$$

a jaabi bɛ bɔ : 8445

O cogo file

i bɛ da foɔ bɔ mansin kan 563

i bɛ sigiyɔɔmali taamashyɛn digi x

i bɛ da filanan bɔ mansin kan 15

i bɛ jaabi dilan digi sɛnɛ kelen =

jaabi bɛ bɔ i kɔɔ 8445

**Tilali kɛcogo**

I bɛ mansin mɛnɛ, ka taamasinyɛn kelen kelen digi, a sɛbɛnnen bɛ cogo min :

$$4 \ 2 \ 5 \ 0 \ - \ 2 \ 5 \ =$$

a jaabi bɛ bɔ : 170

O cogo file :

i bɛ da foɔ mansin kan : 4250

i bɛ tilali taamasinsyɛn digi -

i bɛ da filanan bɔ mansin kan 25

i bɛ jaabi dilan digi =

jaabi bɛ bɔ i kɔɔ 170